



KADMEC[®]
Parts & Accessories

PROFESSIONAL STANDARTS
SINCE 1975

MO20 14

CATALOGUE

YEDEK PARÇA
AKSESUAR
HASAT MAKİNELERİ
DUYARGALI ÇAPALAR

GENEL KATALOG
GENERAL CATALOGUE





Güvencesiyle...

ONLINE POS ÖDEME SİSTEMİ



KREDİ KARTIYLA ÖDEME

İş Bankası Kredi Kartlarına 12 Taksit

www.kadioglumakina.com.tr

Bayi Giriş Bilgilerinizi Öğrenmek İçin: 0224 342 40 33



Firma Profili

Merkezi Bursa'da olan Kadioğlu Makina Ltd. Şti. pekçok ürününün üretimini montajını, depolamasını ve pazarlamasını Otosansit Sanayi sitesindeki 4750 m² kapalı alanda sürdürmektedir. Yine Otosansit Sanayii Sitesinde bir de showroom'u bulunmaktadır.

Ana faaliyet alanlarını bahçe tarımına yönelik hasat makinaları ile toprak işleme makinaları; motorlu tırpan, ağaç kesim motoru gibi açık hava güç ürünlerinin 1000 kalemin üzerinde çeşit yedek parçalarının üretimi ve ithalatı oluşturmaktadır.

Kadioğlu, yıllık cirosunda ürettiği ürünlerin payı ortalama %75, ithalatını yaptığı ürünlerin payı ise %25'dir. Cirosunun %80'ini yurtdışı satış oluşturmaktadır.

Kadioğlu ekibi üretim avantajı olan ürünleri projelendirir, üretir, uygular ve satış sonrası hizmetleri ile müşteri memnuniyetini sağlamayı hedefler.

Kalite Kontrol

İleri teknolojiyi yüksek beceri ile kullanan genç, dinamik ekip koordineli çalışması ile Kadioğlu kalite anlayışını ürünlerine yansıtır.

Satış Sonrası Hizmet

Satış sonrası destek sistemi talebe bağlı olarak Kadioğlu Makina'nın kendisi veya bayileri aracılığıyla müşterilerine anında yanıt vermek üzere kurulmuştur. Firmanın 2014 yılı itibariyle Türkiye de 130 aktif bayii ve 640 firma ile satışa yönelik ticari ilişkisi vardır. Yedek parça ve servis hizmetindeki başarıyı dostlarıyla etkin çalışması getirmektedir.

AR-GE

4 arge mühendisi 10 tecrübeli teknik elemanı ile araştırma ve geliştirmeye verilen önem "Kadioğlu" markasının gelecekte de var olma arzusunun en büyük göstergesidir.

Vizyon

Kaliteden ödün vermeden üretimdeki başarıyı arttırmak.

Misyon

Yaptığımız işin gereğini yaparak milli ekonomiye katkı sağlayan bir firma olmak.

Çalışma İlkesi

Sosyal, ticari ilişkilerde samimiyet ve güven.

Company Profile

Kadioğlu Machinery Co. Ltd. is centered in Bursa/Turkey. It maintains its mounting, storing and marketing in 4750 m² indoor place on Industrial Area. And also a Kadmec showroom is placed in this area.

Main production is harvester and tillage equipments of garden cultivation. And the company's has an active production and import over 1000 sample of spare parts of outdoor power products

The annual turnover of Kadmec consists of %75 its production and %25 imported products.

Income of company depends on %80 percent domestic sales.

The Kadmec makes project on products to have production advantage then produce them and makes good relation with its customer after selling.

Quality Control

With usage of advanced technology, the dynamic team works in kordinel way to project in Kadmec vision.

After Sales Service

The after sales service of Kadmec is founded with aims of making respose to customer in a short time by itself or its seller.The company has 130 active seller and relation with 640 firm for sale in 2014.The achievement of company depends on a good group working with its collaborator.

R & D

Having 4 R&D engineers and 10 experienced technical staff and giving importance to researching and development are the biggest signs of the desire of have future for KADMEC.





Değerli meslektaşlarımız,

Aradığınız her ürünü rahatlıkla bulabilmeniz için düzenlediğimiz 2014 kataloğumuzda perakende satışta yardımcı olabilmesi için pek çok ürün grubunun iskontosuz fiyatlarını belirttik. İmalatını ve distribütörlüğünü yaptığımız makina grubu tanıtımlarını da ön sayfalarda bulabilirsiniz.

Kalitede süreklilik bizim için önemli. Bu yıl Kadioğlu Makina için yatırım yılı oldu yatırımlarımızla üretim kapasitemizi, teknolojimizi arttırdık. Ürünlerimizi Bursa'da üretim yapan Tofaş, Renault, Bosch gibi firmaların tercih ettiği patentli malzemelerle üretiyor, her geçen gün sizlerin talepleri doğrultusunda ürün çeşitliliğimizi arttırıyoruz.

12 Farklı ülkeye ihracat gerçekleştiren Kadioğlu Makina olarak, teknik altyapı ve titiz üretim gerektiren ürünleri sizin için üretmeye hazırız.

2014 yılının hepimiz için bereketli bir yıl olmasını dileklerimizle...



BİZDEN KARELER // OUR COMPANY





İÇİNDEKİLER // INDEX

MAKİNE, ALET VE ÜRÜN TANITIMLARI MACHINES & EQUIPMENT INTRODUCTION	5 - 18
MOTORLU TIRPAN AKSESUAR VE YEDEK PARÇALARI BRUSHCUTTER ACCESSORIES & SPARE PARTS	
• MOTORLU TIRPAN KESİCİ BAŞLIKLARI // TRIMMER HEADS	19 - 35
• MOTORLU TIRPAN KESİCİ BAŞLIK YEDEK PARÇALARI // TRIMMER HEADS SPARE PARTS	36 - 41
• GÜVENLİK VE AKSESUARLAR // PROTECTION AND ACCESSORIES	42 - 46
MOTORLU TIRPAN YEDEK PARÇALARI BRUSHCUTTER SPARE PARTS	
• ALPINA - CASTOR / CASTEL - GARDEN	47 - 54
• DOLMAR	54
• HQ / JON	55 - 56
• KAWASAKI	57 - 59
• KNC	60
• OLEO - MAC / EFCO / ERGO	61 - 73
• (PRC) PALMERA / SECHO / ORAC / ENERGY VE MITSUBISHI	74 - 85
• STIHL	86 - 89
• SİRİRAL HORTUM // FLEXIBLE SHAFT	89 - 91
• BENZİN HORTUMU // FUEL HOSE	92
• SİRİRAL MİL // FLEXIBLE DRIVE SHAFT	93
ÇİM BİÇME MAKİNESİ YEDEK PARÇALARI LAWN MOWER SPARE PARTS	
• ÇİM BİÇME BİÇAKLARI // LAWN MOWER BLADES	96 - 99
• BENZİNİLİ // GASOLINE POWERED	100 - 104
• ELEKTRİKLİ // ELECTRICAL POWERED	105
İLAÇLAMA MAKİNESİ YEDEK PARÇALARI MISTBLOWER & KNAPSACK POWER SPRAYERS SPARE PARTS	
• SIRT TİPİ PULVERİZATÖR (P.R.C.) // KNAPSACK POWER SPRAYERS	108 - 110
• ATOMİZÖR (P.R.C.) // MISTBLOWER	111 - 116
KESİM MOTORU YEDEK PARÇALARI CHAINSAW SPARE PARTS	
• AKSESUAR // ACCESSORIES	118
• ALPINA	118 - 119
• DOLMAR	119 - 120
• HQ	121 - 127
• JON	127 - 131
• MCCULLOCH	131
• OLEO - MAC / EFCO	132 - 133
• STIHL	134 - 137
• P.R.C.	137
ÇAPA MAKİNESİ YEDEK PARÇALARI TILLER SPARE PARTS	139 - 145
ZEYTİN TOPLAMA MAKİNESİ YEDEK PARÇALARI OLIVE HARVESTER SPARE PARTS	147 - 151

EMR-400 ZEYTİN TOPLAMA MAKİNESİ // EMR-400 HARVESTER

PAKET İÇERİĞİ / INCLUDED



Zeytin Silkeleme Aparatı
Olive Harvester Gearcase



Kanca
Hook



2 Yedek Kanca Lastiği
Hook Rubber (2 Pieces)



Tırpan Bıçağı
Blade (4T)



Ot Biçme Aparatı
Brush Cutter Comp.



Kullanımına göre, günde 1 ton'dan 3,5 ton'a kadar hasat sağlayabilen ekonomik bir araçtır.

4 - 5 metreye kadar ulaşımaya olanak sağlar. Titreşim sağlayan silkeleme aparatının motordan ayrı olması ve motorun sırtta taşınması kullanıcının koluna binen gereksiz yükü azaltarak, kullanım rahatlığı ve pratikliği sağlar.

Rahatlıkla değiştirilebilir ot biçme aparatı ile zeytinciler için önemli olan zeytin silkeleme ve tırpan tek makine üzerinde kullanılabilir. (Ot biçme ekipmanı ürüne dahildir.) 2 Yıl servis garantilidir.

It is an economical device that provides harvest from 1 to 3,5 tons a day depending on the usage. It provides a range of reach upto 4-5 meters. Shaking apparatus providing vibration being apart from the motor and the motor being carried at the back lessens the unnecessary load born by the arm of the user and gives an ease of use and practicality.

With easily exchanged bush cutting apparatus, it is able to be used for olive harvesting machine and brush cutter which is significant for olive growers.

(Brush cutting apparatus included in the equipment) It is 2-years under service guarantee.

Ergonomik sırtlığı kullanıcıya ağırlığı en az hissettirerek, en rahat şekilde hareket etmesini sağlayacak şekilde dizayn edilmiştir.

The ergonomic backpack is designed to provide the user least perception of the weight and to move most comfortably.



TEKNİK ÖZELLİKLER / TECHNICAL APPLICATIONS

Motor / Engine	: Alpina - Castor - Oleo - Mac - PRC
Ağırlık / Weight	: 8,4 Kg.
Kolu Etkileyen Ağırlık / Weight On Arm	: 3,8 Kg
Güç / Power	: 3.0 HP
Vibrasyon Hızı / Vibration Speed	: 3.000 devir/dk.



Rahatlıkla değiştirilebilir ot biçme aparatı ile zeytin silkeleme ve tırpan tek makine üzerinde kullanılabilir. (Ot biçme ekipmanı ürüne dahildir.)

With easily exchanged bush cutting apparatus, it is able to be used for olive harvester and brush cutter (brush cutting apparatus included in the equipment)





**Yüksek Teknoloji
ile
Kaliteli İşçiliğin
Buluşması...**

% 100 TÜRK MALI

U biçiminde kanca tasarımı.
Yüksek devirlerde kanca
daldan kurtulmaz.

**Özel ayarlanmış kauçuk
sertliği.** Kabuk soyamaz
anahtar kullanmadan
değiştirilebilir.

Özel kızak sistemi.
İç mekanizmanın parça sayısını
azaltıp dayanıklılığını artırarak
makine ömrünü uzatmıştır.

**Şanzumanın makinenin uç
kısmında olması.**
Vibrasyon yaratan sistemin
dala yakın olmasını sağlayarak
dökme performansını
maksimum seviyeye taşır.



Pek çok ağacı hasat etmek için büyük bir makineye ihtiyaç yoktur. Daha hafif (6,8 kg) ve ekonomik bir makine işinizi fazlasıyla görür.

**Biz de bu yüzden
EMR-400 Light'ı
tasarladık...**



Verimli çalışma için.



Teknik Özellikleri

Motoru ile komple ağırlığı : 6,8 kg.

Motor gücü : 1,1 hp

Vibrasyon hızı : 3000 Devir / dk.

Garanti süresi : 2 yıl

- Kadioğlu EMR-400 Zeytin Silkeleme makinesinin daha hafif, küçük versiyonudur. Bu makine ana hasat makinesine yardımcı niteliktedir.
- Büyük ve yandan motorlu 14 - 18 kg'lık makinelerin aksine merdiven ile çalışmak ve dal gezmek oldukça rahattır. İsterseniz makineyi tek elinizle dahi kaldırıp istediğiniz dalı ağzlayabilirsiniz.
- Makinenin taşıma sapı ve tetik tertibatı hissettiğiniz titreşimi en aza indirebilmek için çift amortisörlü olarak dizayn edilmiştir. Ergonomik askısı da taşımamızda kolaylık sağlayacaktır.



ELEKTRİKLİ ZEYTİN HASAT MAKİNESİ

Octo electric
PNEUMATIC SYSTEMS
POWERED BY HONDA



45 cm



Octo taraklı hasat makineleri serisinin yeni üyesiyle tanışın... Octo Electric.

• Karbonfiber çubukludur. Sopası dahil toplam ağırlığı 2 kg'dır.

• 12 V akü ile çalışır. Traktör, otomobil veya motosiklet aküsüyle çalışabilir.

• Enerji tüketimi minimum düzeydedir.

• Ek uzatma aparatları mevcuttur.

• Hız ayarı mevcuttur. Zeytin baskınlığı, dal yapısına göre istenilen hızda çalıştırılabilir.

• Kullanıcıya hissettirdiği titreşim en alt seviyededir. Bu da uzun süreli çalışmaya olanak tanır.

HASAT MAKİNELERİ

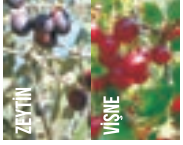

Octo benzin
PNEUMATIC SYSTEMS
POWERED BY HONDA

• Karbonfiber çubukludur.

• Benzinli motoru ile profesyonel kullanıma uygundur. Uzun süre aralıksız çalışabilir.

• İstenilen devirde çalıştırabilir.

• Benzin motoru sırtta, ergonomik askısıyla taşındığı için kullanıcının koluna binen yük azaltılmıştır.



OCTO KOMPRESÖR // OCTO COMPRESOR

POWERED by
HONDA

Çekmeli Tip
Pull Type



Kendi Motorundan Güç Alarak
İlerleyebilen Tip
Moveable Compressor System
With Own Energy



TEKNİK ÖZELLİKLER / TECHNICAL DETAILS

Motor / Engine	: HONDA GX 200
Motor Gücü / Engine Power	: 6 HP
Basınç / Pressure	: 13 Bar max
Tavsiye edilen Basınç / Advised	: 7 Bar
Jak Çıkış Sayısı / Number of Jacks	: 4
Hava Çekışı / Air Suction	: 600 lt / min

Bu makinede basınçlı hava ile çalışan taraklı zeytin sıyrma aparatı ile hasat, budama makasları ile budama yapılmaktadır.

Az Zaman Çok İş

Standart olarak 4 jak çıkışı vardır. 2 zeytin sıyrma tarağıyla aynı anda hasat yapılabilir.

Güçlü Gövde Yapısı, Hafif ve Uzun Taraklar,

Kompresörün gövde yapısı güçlü ve oturaklıdır.

5-6 metre uzayabilen, hafif teleskobik tarakları ile yüksek dallara ulaşım zahmetsizdir.

Sadece Zeytin Hasat Değil !

Standart ölçülerde jak girişleri sayesinde uyumlu pek çok pnömatik alet ile beraber kullanılabilir. (Boya Makineleri, matkap vs.)

Tüm Aksamı 2 Yıl Yedek Parça ve Servis Garantilidir.

KADMEC Industrial compressors are used for harvesting, pruning and maintenance of vineyards, olive groves and orchards.

Less time, More work.

There are four Jacks on machine. You can work with four olive harvester rods at same time. (You can increase jack number by components)

Strengest frame and Light Rods

The frame of machine made by strongest material. You can reach long branches (6 meters) with light telescopic rods.

Not only for Olive Harvesting

You can use all of pneumatic equipments because of jacks standart diamentions.

(Painting, pruning, drilling...etc)

All parts are 2 years under quarantine.

HASAT MAKİNELERİ

MEYVE HASATINI HIZLANDIRMANIN EKONOMİK YOLU



**CEVİZ'de
%97
DÜŞÜRME
BAŞARISI**

**Kuyruk Miliyle
Çalışan
Ekonomik
Sarsıcı**

Vibrope



HASAT MAKİNELERİ



**TELESKOPIK
KOLU
MERDİVENSİZ
7 mt.
YÜKSEKLİĞİNDE
DALLARA
BAĞLANABİLİR**



Kadioğlu Vibrope Halatlı Meyve Hasat Makinası

Kadioğlu Vibrope, kalın dalların yada genç ağaçların gövdelerinin sarsılarak meyvesinin düşürülmesi yoluyla hasatın hızlandırılması amaçlanmış ekonomik bir hasat makinasıdır.

Traktörün arkasına monte edilen gücünü kuyruk milinden alan, 15 hp ve üzeri tüm traktörler ile rahatlıkla çalışabilen bir sistemdir.

Özel kemeri ile ağacın ana dallarına bağlanır ve halat gergin hale getirilir. Kuyruk mili harekete geçirildiğinde istenilen devirde sarsma işlemi yapılır.

Kayısı, Ceviz, Badem, Vişne, Zeytin, Portakal, Limon ve diğer pek çok meyveyi toplarken işi oldukça hızlandırır ve kolaylaştırır.

Ekonomik bir model olması sebebiyle küçük çapta üretim yapan çiftçiler dahi rahatlıkla ulaşabilir. kurulumu basit, kullanımı kolaydır.

DİP ZEYTİNİ TOPLAMA ALETİ // OLIVE PICKER

Kirpi
Toplamak onun işi

**YENİ
SİSTEM**



Dip Zeytini Toplama Aleti

- Günlük 1 Ton Kapasite
- Uzun Ömürlü
- Üstün Manevra Yeteneği
- 2 Yıl Garantili

ÜRÜN TOPLAMA TERTİBATI / KIRPI

MATERIAL COLLECTION MECHANISM / PORCUPINE



Kirpi Nedir?

Kirpi bir toplama aletidir. Kullanımı basit, pratik bir saplama - sıyırma mekanizmasıdır. Tarımsal alanlarda yere düşmüş ürünün veya park, bahçe, piknik alanları, yol kenarları, refüjler, sahiller gibi alanlarda atık maddelerin toplanmasına yardımcı olan bir toplama tertibatıdır. Meyve, çöp ve yaprak gibi atık yada değerlendirilebilecek maddelerin yerden toplanması için eğilmeden ve zahmetsizce toplamayı sağlayabilen kullanımı kolay olan bir yapıya sahiptir.

What is a porcupine?

A porcupine is a device used for collection. It is a simple and practical stabbing-scraping mechanism. It is a collecting mechanism which helps the collection of crop fallen on the ground on farming areas or the waste materials in the parks, gardens, picnic areas, roadsides, refuges, beaches. It has a easy to use structure preventing to bent down while collecting the wastes such as fruit, trash and leaves or recyclable materials.

Spedo Fruipick
traktöre monte edilen,
tam otomatik ve güçlü bir ağaç
gövdesi sarsıcısıdır.
Yaygı şemsiyesi takıldığında dökülen
meyveyi şemsiye biçimde otomatik açılan
yaygısına toplar.
Yine otomatik bir biçimde açılan alt kapağı
vasıtasıyla istenilen yere boşaltır.
Tüm bunları yaparken traktörün üstünde
olmanız gerekmez, herşey uzaktan
kumanda kontrolündedir.
70 Hp ve üzeri tüm marka ve model
traktörlere uyumludur.

Uzaktan kumandasıyla
daha rahat bir kontrol
imkanı sağlar.



**Zeytin, Kayısı, Ceviz, Badem,
Antepfıstığı, Vişne, Portakal**

HASAT MAKİNELERİ



Özel sarılma sistemi ile ince dallar ayrı ayrı sarılabilir.

- Makinenin traktöre bağlı olması, ağaç gövdesi ya da anadal'ın kavisi yapısı, sarsıcının hareketini kısıtlamaz.
- 6 metreye kadar her yöne uzayabilen hareketli kolu ve sarsıcı kafası istenilen açıdan anadal ya da ağaç gövdesine sarılabilir,
- Traktörü hareket ettirmeden sadece uzaktan kumanda ile yönlendirilerek 3 - 4 ağaç hasat edilebilir.
- Titreşim başlığı hidrolik motorlarla kontrol edilir istenilen şiddette sarsar. Saat yönüne ve saat yönünün tersine titreşim verebilir buda hasat performansı artırır.
- Sarsıcı kafanın, gövdeye kauçuk takozlarla bağlanmış olması hasat verimini artırır. Ağaç kabuğuna zarar vermesini engeller.
- Ürüne yaygı şemsiyesi takıldığında dökülen meyveyi ters şemsiye biçiminde olan haznesine toplar ve otomatik açılan alt kapağı vasıtasıyla istenilen yere boşaltır.



**Nitelikli
Profesyonel
Çözüm**

EMRE 5500 ÇAPALAMA MAKİNESİ // TILLER

EMRE5500 tarımsal üretimde, büyük ve hantal araçlara veya maliyetli bilek gücüne ekonomik ve başarılı bir alternatif sunar. Motorlu çapanın şasesi tamamı Kadioğlu Makine imalatı olup, kalitesi kanıtlanmış HONDA motor kullanılmıştır. Sınıfının en ağır, en mukavemetli ve en az yüksekliğe sahip makinesidir (60cm).

- * Sınıfının en alçak ve ağır makinesidir. Bahçe Tipidir, Seralar İçin Birebirdir.
- * Günde 1.7 Dönüm alan çapalayabilecek bir üründür.
- * Çapalama Esnasında Hız Ayar Ve Kontrol Düzenlerine Sahiptir.
- * Kendine özgü kavıslı bıçak yapısı motora binen gereksiz yükü ve bıçak kırılmalarını azaltır, arazide kullanıcıya verimli iş ve şaşırtıcı derecede toprak karıştırma yeteneği sunar.
- * Alçak ve dinamik yapısıyla dar, Eğimli, ve İşlenmesi zor Arazi Şartlarında Etkili Performans Sağlar.
- * Çapalama alanı genişliği rahatlıkla kısaltılıp uzatılabilir.
- * Özel çapa şekli ile plastik yanaklar ağaç dibi çapası yaparken ağaç kabuğuna zarar vermez, Ağaç diplerinde çalışırken kabuk sıyırmaz.
- * Portatif Taşıma Tekerlekleri Vardır.
- * Opsiyonel pulluk aparatı ile karık açmanıza olanak sağlar.
- * Zorlu alanlarda daha etkili performans için ek ağırlık seçeneği mevcuttur. (20 kg)
- * Standart olarak Anadolu motordan 2 yıl garantili Honda motor kullanılmaktadır ve ürün 2 yıl servis garantilidir. Tercihen farklı motor seçenekleriyle sunulabilir.

EMRE5500 offers an economic and a successful alternative to the big and ponderous devices or costly manpower in the agricultural production. The chassis of the tiller is manufactured by Kadioğlu Makine and HONDA motor with proven quality is used. It is the heaviest, most high-strength and lowest machine of its class. (60cm)

- * The heaviest and the lowest machine of its class. Garden type. Most efficacious for the greenhouses.
- * It is a product able to hoe an area of 1,7 deceres a day.
- * It has adjustable speed and control mechanisms during hoeing.
- * Specific curved knife structure decreases the unnecessary load on motor and knife breaks, it offers a productive work on the land and an incredible ability to mix the soil.
- * It provides an efficient performance on narrow, inclined and hard to cultivate land conditions with its low and dynamic structure.
- * The hoeing widht can be shortened or prolonged easily.
- * The plastic sides do not harm the bark while making tree bottom hoeing. It does not scrape the bark while working at tree bottoms.
- * It has portable movement wheels.
- * Additional weight can be mounted. (20 kgs)
- * It provides you opportunity to open furrow with optional plough apparatus.
- * It has additional weight options for better performance on harder areas.
- * Honda motor is used as Standard having a 2-years guarantee of Anadolu Motor and the product has a 2-years service guarantee. Preferably, it may be presented with different motor options.

TEKNİK ÖZELLİKLER TECHNICAL APPLICATIONS

Motor / Engine	: Honda GX160
Ağırlık / Weight	: 58 kg
Çapalama Derinliği / Work Depth	: 25 cm
Çapalama Genişliği / Work Width	: 88 cm
Güç / Power	: 5,5 HP





Yabancı ot mücadelesini ilaç ve insan gücü olmadan keyifle yapmanızı sağlar



Sade, sağlam, zekice tasarımıyla hızlı ve sorunsuz çalışan Kadioğlu Duyargalı çapalar binlerce bağ / meyve dibini otomatik olarak işlemeye her zaman hazır.

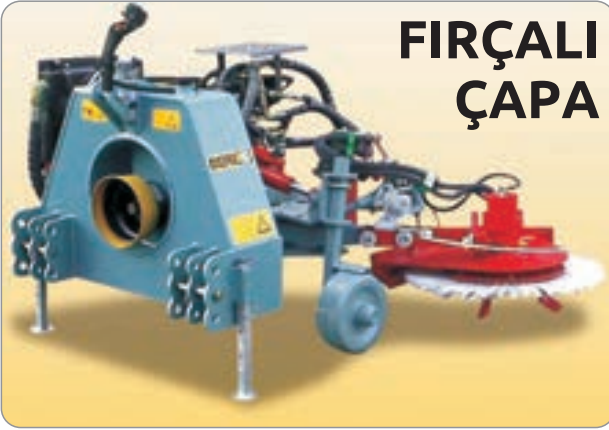

FIRÇALI ÇAPA

RADYATÖRLÜ MODEL, MARS

Hidrolik yağ soğutucu radyatörü ile özellikle zor arazi şartları için ya da büyük ölçekte üretim yapanlar tarafından tercih edilir. Hidrolik mekanizması darbeleri rahatça emer. Kesici, doldurucu, döner, ot temizleyici, bıçaklı onlarca çeşit ekipman monte edilebilir. En az 35 beygirlik traktörler ile çalışabilir.

DÖNERLİ

SABİT



ÇALIŞTIRDIĞI ATAŞMANLAR

EKO EKONOMİK MODEL, EKO



Bağ ve bahçeler için ideal ekonomik modelimizdir. Kesici takımlar (Diskaro, kesici bıçak) ile çapalama işlemini gerçekleştirir. Basit Hidrolik aksamı itibarıyla 35 beygir ve üzeri traktörlerle çalışabilir. Kesici ve doldurucu ekipmanlar monte edilebilir.

KADIOĞLU - SPEDO DUYARGALI (SENSÖRLÜ) TOPRAK İŞLEME MAKİNALARI

Kadioğlu, duyargalı (sensörlü) bağ arası (ağaç arası) çapa makinaları ile çapalama işine yeni bir soluk getiriyor. Duyarga sistemi sayesinde bitki diplerine kolayca girebilir, ağaç aralarını ve diplerini hızlıca çapar. İşçiliği %95'e kadar oranında azaltan, ot mücadelesini mekanikleştirdiği için çevre dostu çözüm sunan sistemlerdir.

Bitki/Ağaç aralıklarına kolayca girebilir; 40 cm'e kadar ağaç aralarında iş yapabilir.

Kadioğlu duyargalı (sensörlü) toprak frezeleri, çapalama makinaları, kaydırmalı diskaroları diğer sistemlerden 10'larca farklı ekipmanıyla bir adım öne çıkmaktadır. Aynı sistemi uygun kesici, döner, doldurucu, temizleyici - çapalayıcı gibi takımlar takarak kullanabilirsiniz.

Tamamı hidrolik olan mekanizmalarıyla, mekanik çalışan aletlere nazaran daha hassas, daha güvenilir ve daha uzun ömürlüdür.

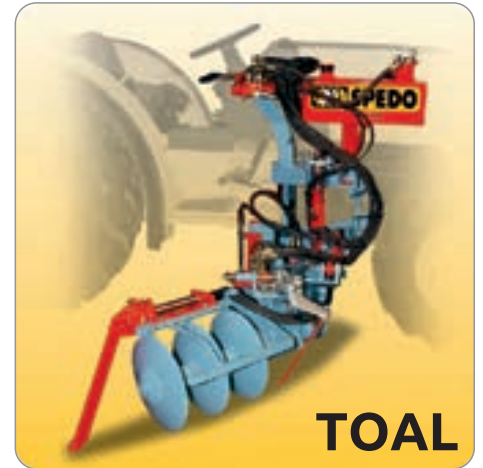

TOAL

YANDAN MONTELİ; TOTAL

Traktöre yan bölümden monte edilir. Pekçok ekipman ile birlikte çalışabilir. Kesici, doldurucu, döner, ot temizleyici, bıçaklı onlarca çeşit ekipman monte edilebilir.

ÇİM EZME SİLİNDİRİ // GARDEN ROLLER

Garden Roller çelik gövdesi ve hem su hem de kum ile doldurulmaya müsait yapısı ile çimlerinizi silindire sıkıştırma işini kolaylaştırır veya tohumların rüzgar tarafından uzaklara götürülmesini veya kuşların yemesini engelleyecek biçimde tohumları presler.

Her zaman Temiz

Garden Roller 100% su geçirmez olan yüksek kaliteli bir silindirdir ayrıca kazıma çubuğu ile de çamur birikintilerinden korunur.

Şeritli Etki

Garden Roller çimenlerin üzerinde hafifçe şeritli bir görüntü etkisi bırakırken aynı zamanda toprağı yavaşça sıkıştırır.

Sıkıştırma

Garden Roller muhtelif miktarlarda zemin basıncı için kum veya su ile doldurulabilir ve toprak yüzeyini hafifçe sıkıştırır.



Garden Roller with its steel body and ability to be filled by either water or sand makes for easy rolling of your lawn or to simply press seeds down into the soil preventing them from being blown away or eaten by birds.

Always Clean

Garden Roller is a quality roller which is 100% watertight, it also features a scraper bar to keep the roller free from debris.

Striped Effect

Garden Roller leaves a lightly striped effect on the lawn for a formal appearance, while gently compacting the earth at the same time.

Compacting

Garden Roller can be filled with either sand or water for varying amounts of ground pressure which lightly compacts the grounds surface.

ÇİM TIRMIĞI // GARDEN RAKE

Çim alanlarda zemine ince çizikler atmak sureti ile çim alanların havalanmasını sağlar. Çim diplerindeki keçeleşmeyi önler. Kurumuş çim atıklarını temizler, ve böylece çimi yosun ve mantarlardan arındırır. Sağlıklı çim alanlar elde etmek için fevkalade gereklidir.

Çalışma Genişliği: 32 cm

Teleskopik sap sayesinde 85 - 170 cm arası istenilen boyda çalışma imkanı vardır.

It provides ventilation of the lawn fields by making thin scratches on the ground of the lawn fields. It prevents the lawn bottoms to get slight softened. It will remove the dead lawn wastes and so the lawn is isolated from moss and fungus. It is so essential to acquire healthy lawn fields.

Working Width: 32 cms.

It provides a facility to work with desired length between 85 - 170 cms with the help of a telescopic handle.



OT - FINDIK TIRMIđI // GRASS RAKE

SAPSIZ TIRMIK

RAKE

KOD [CODE]: BA.001

10.00 TL

SAPLI TIRMIK

RAKE WITH STICK

KOD [CODE]: BA.002

13.00 TL



Esnek, kırılmaya ve aşınmaya dayanıklı hafif tirmikler...



ÖZELLİKLERİ / APPLICATIONS

220 Volt Ev elektriđiyle kullanılır

It can be used with home electric

Güç / Power : 1.5 KW

Devir / RPM : 2800 devir/dk

Elmaslı Bıçak

Blade with Diamond

Ayarlı Gönye

Adjusted Mitre

Herkesin rahatlıkla kullanabileceđi amatör bir modeldir. Ev elektriyle çalıřır. Elektrik olan yerlerde balta yerine kullanılabilirerek iřin zahmetini ve kullanılan eforu azaltır. Ev ve iř için gerekli çeřitli profiller kesilerek günlük hayatı kolaylařtırır. Ayarlı gönyesi sayesinde istenilen kalınlıklarda kesim yapmak mümkündür.

It is an amateur model that can be used by everyone. It works with home electric.

In place where included electric, it is an easy device instead of axe and it increases your effort. It makes easy your work and personal life by cutting some type of profiles. It is possible cut different diamentions which you want with adjusted mitre.

MOTORLU TIRPAN AKSESUAR VE YEDEK PARÇALARI

BRUSH CUTTER ACCESSORIES & SPARE PARTS



STANDART TİP BAŐLIK YENİ // TAP AND CUT CLASSIC PRO



Gövdesinde dişli gurubuna ot sarılmasını engelleyen set vardır.
Özel malzemesiyle zorlu kesim şartlarına uygundur.
Kırılma yapmaz. Aşınarak yıpranır.

It is suitable for heavy duty gardening with its strong material.

OLEO-MAC / EFCO, KAWASAKI, MITSUBISHI, HONDA, HITACHI KNC, SECHO, ORAC, PALMERA, BACO, FARMATE, FARMER, ENERGY VE DİĞER PRC ÜRETİMİ TIRPANLARA UYUMLU MODEL
EFCO, PRC BRUSHCUTTERS

KOD [CODE]: T.OB.101

16.00 TL

ALPINA / CASTOR, OLEO - MAC / EFCO ESKİ MODEL (8 MM, TERS DİŐ CİVATA ERKEK)
ALPINA, EFCO OLD MODELS (8 MM BOLT)
KOD [CODE]: T.OB.102

16.00 TL

STIHL YAN MODEL 40/2, FS
STIHL STRAIGHT SHAFT MODEL

KOD [CODE]: T.OB.103

16.00 TL

STIHL SIRT MODEL 30/2, FR
STIHL FLEXIBLE SHAFT MODEL

KOD [CODE]: T.OB.104

16.00 TL

HQ, JONSEREDS YAN - SIRT
HQ, BOTH SHAFT MODELS

KOD [CODE]: T.OB.105

16.00 TL

DOLMAR
DOLMAR

KOD [CODE]: T.OB.106

16.00 TL

MITSUBISHI - KAAZ
MITSUBISHI - KAAZ

KOD [CODE]: T.OB.107

16.00 TL

SHINDAIWA YAN
SHINDAIWA, STRAIGHT SHAFT MODEL

KOD [CODE]: T.OB.108

16.00 TL

SHINDAIWA SIRT
SHINDAIWA, FLEXIBLE SHAFT MODEL

KOD [CODE]: T.OB.109

16.00 TL

SOLO
SOLO

KOD [CODE]: T.OB.110

16.00 TL

KOMATSU
KOMATSU

KOD [CODE]: T.OB.111

16.00 TL

STANDART TİP BAŐLIK // TAP AND CUT CLASSIC



Özel malzemesiyle zorlu kesim şartlarına uygundur.
Kırılma yapmaz. Aşınarak yıpranır.

It is suitable for heavy duty gardening with its strong
material.

**OLEO-MAC / EFCO, KAWASAKI, MITSUBISHI,
HONDA, HITACHI KNC, SECHO, ORAC, PALMERA,
BACO, FARMATE, FARMER, ENERGY VE DİĞER
PRC ÜRETİMİ TIRPANLARA UYUMLU MODEL**

EFCO, PRC BRUSHCUTTERS

KOD [CODE]: T.OB.001

16.00 TL

**ALPINA / CASTOR, OLEO - MAC / EFCO ESKİ MODEL
(8 MM, TERS DİŐ CİVATA ERKEK)**

ALPINA, EFCO OLD MODELS (8 MM BOLT)

KOD [CODE]: T.OB.002

16.00 TL

STIHL YAN MODEL 40/2, FS
STIHL STRAIGHT SHAFT MODEL

KOD [CODE]: T.OB.003

16.00 TL

STIHL SIRT MODEL 30/2, FR
STIHL FLEXIBLE SHAFT MODEL

KOD [CODE]: T.OB.004

16.00 TL

HQ, JONSEREDS YAN - SIRT
HQ, BOTH SHAFT MODELS

KOD [CODE]: T.OB.005

16.00 TL

DOLMAR
DOLMAR

KOD [CODE]: T.OB.006

16.00 TL

MITSUBISHI - KAAZ
MITSUBISHI - KAAZ

KOD [CODE]: T.OB.007

16.00 TL

SHINDAIWA YAN
SHINDAIWA, STRAIGHT SHAFT MODEL

KOD [CODE]: T.OB.008

16.00 TL

SHINDAIWA SIRT
SHINDAIWA, FLEXIBLE SHAFT MODEL

KOD [CODE]: T.OB.009

16.00 TL

SOLO
SOLO

KOD [CODE]: T.OB.010

16.00 TL

KOMATSU
KOMATSU

KOD [CODE]: T.OB.011

16.00 TL

BÜYÜK TİP BAŞLIK // TAP AND CUT BOSS



Diğer başlıklara göre daha uzun misina sarılabilir.
Özel malzemesiyle zorlu kesim şartlarına uygundur.

High capacity wire
It is suitable for heavy duty gardening with its strong material.

**OLEO-MAC / EFCO, KAWASAKI, MITSUBISHI,
HONDA, HITACHI KNC, SECHO, ORAC, PALMERA,
BACO, FARMATE, FARMER, ENERGY VE DİĞER
PRC ÜRETİMİ TIRPANLARA UYUMLU MODEL**

EFCO, PRC BRUSHCUTTERS

KOD [CODE]: T.OB.501

32.00 TL

**ALPINA / CASTOR, OLEO - MAC / EFCO ESKİ MODEL
(8 MM, TERS DİŞ CİVATA ERKEK)**

ALPINA, EFCO OLD MODELS (8 MM BOLT)

KOD [CODE]: T.OB.502

32.00 TL

STIHL YAN MODEL 40/2, FS
STIHL STRAIGHT SHAFT MODEL

KOD [CODE]: T.OB.503

32.00 TL

STIHL SIRT MODEL 30/2, FR
STIHL FLEXIBLE SHAFT MODEL

KOD [CODE]: T.OB.504

32.00 TL

HQ, JONSEREDS YAN - SIRT
HQ, BOTH SHAFT MODELS

KOD [CODE]: T.OB.505

32.00 TL

DOLMAR
DOLMAR

KOD [CODE]: T.OB.506

32.00 TL

MITSUBISHI - KAAZ
MITSUBISHI - KAAZ

KOD [CODE]: T.OB.507

32.00 TL

SHINDAIWA YAN
SHINDAIWA, STRAIGHT SHAFT MODEL

KOD [CODE]: T.OB.508

32.00 TL

SHINDAIWA SIRT
SHINDAIWA, FLEXIBLE SHAFT MODEL

KOD [CODE]: T.OB.509

32.00 TL

SOLO
SOLO

KOD [CODE]: T.OB.510

32.00 TL

BİLYALI BAŞLIK // TRIMMER HEAD WITH BEARING



Zemine temas eden parçası dönmediği için motoru rahatlatır. Kullanıcıya rahat çalışma imkanı sunar. Yedek parçaları her zaman stoklarımızdadır. Özel malzemesiyle zorlu kesim şartlarına uygundur.

It gets the engine relaxed be cause of obstructing the friction.
Spore parts are always in stock
It is suitable for heavy duty gardening with its strong metarial.

OLEO-MAC / EFCO, KAWASAKI, MITSUBISHI, HONDA, HITACHI KNC, SECHO, ORAC, PALMERA, BACO, FARMATE, FARMER, ENERGY VE DİĞER PRC ÜRETİMİ TIRPANLARA UYUMLU MODEL
EFCO, PRC BRUSHCUTTERS

KOD [CODE]: T.OB.201

39.00 TL

ALPINA / CASTOR, OLEO - MAC / EFCO ESKİ MODEL (8 MM, TERS DİŞ CİVATA ERKEK)
ALPINA, EFCO OLD MODELS (8 MM BOLT)
KOD [CODE]: T.OB.202

39.00 TL

STIHL YAN MODEL 40/2, FS
STIHL STRAIGHT SHAFT MODEL

KOD [CODE]: T.OB.203

39.00 TL

STIHL SIRT MODEL 30/2, FR
STIHL FLEXIBLE SHAFT MODEL

KOD [CODE]: T.OB.204

39.00 TL

HQ, JONSEREDS YAN - SIRT
HQ, BOTH SHAFT MODELS

KOD [CODE]: T.OB.205

39.00 TL

DOLMAR
DOLMAR

KOD [CODE]: T.OB.206

39.00 TL

MITSUBISHI - KAAZ
MITSUBISHI - KAAZ

KOD [CODE]: T.OB.207

39.00 TL

SHINDAIWA YAN
SHINDAIWA, STRAIGHT SHAFT MODEL

KOD [CODE]: T.OB.208

39.00 TL

SHINDAIWA SIRT
SHINDAIWA, FLEXIBLE SHAFT MODEL

KOD [CODE]: T.OB.209

39.00 TL

SOLO
SOLO

KOD [CODE]: T.OB.210

39.00 TL

KOMATSU
KOMATSU

KOD [CODE]: T.OB.211

39.00 TL

AKILLI SARMALI BAŞLIK // EASY LOAD WITH GUIDE



**KULLANIM
ÖMRÜ
BOYUNCA
KIRILMAYA
KARŞI
GARANTİLİ**

3.3 mm. Misina rahatlıkla sarılabilir.
Tüm yedek parçaları stoklarımızdadır.
Özel malzemesiyle zorlu kesim şartlarına uygundur.

Easy to load 3.3 mm line
It is suitable for heavy duty gardening with its strong material.

Her hangi bir sökme takma işlemi olmadan misina dışarıdan sokulup ortalanır.

No need to demontage for filling line



Makarasını çevirerek misina sarma işlemi tamamlanır.

You can fill the line by only rotating the reel.



**OLEO-MAC / EFCO, KAWASAKI, MITSUBISHI,
HONDA, HITACHI KNC, SECHO, ORAC, PALMERA,
BACO, FARMATE, FARMER, ENERGY VE DİĞER
PRC ÜRETİMİ TIRPANLARA UYUMLU MODEL**

EFCO, PRC BRUSHCUTTERS

KOD [CODE]: T.OB.401

21.00 TL

**ALPINA / CASTOR, OLEO - MAC / EFCO ESKİ MODEL
(8 MM, TERS DİŞ CİVATA ERKEK)**

ALPINA, EFCO OLD MODELS (8 MM BOLT)

KOD [CODE]: T.OB.402

21.00 TL

STIHL YAN MODEL 40/2, FS
STIHL STRAIGHT SHAFT MODEL

KOD [CODE]: T.OB.403

21.00 TL

STIHL SIRT MODEL 30/2, FR
STIHL FLEXIBLE SHAFT MODEL

KOD [CODE]: T.OB.404

21.00 TL

HQ, JONSEREDS YAN - SIRT
HQ, BOTH SHAFT MODELS

KOD [CODE]: T.OB.405

21.00 TL

DOLMAR
DOLMAR

KOD [CODE]: T.OB.406

21.00 TL

MITSUBISHI - KAAZ
MITSUBISHI - KAAZ

KOD [CODE]: T.OB.407

21.00 TL

SHINDAIWA YAN
SHINDAIWA, STRAIGHT SHAFT MODEL

KOD [CODE]: T.OB.408

21.00 TL

SHINDAIWA SIRT
SHINDAIWA, FLEXIBLE SHAFT MODEL

KOD [CODE]: T.OB.409

21.00 TL

SOLO
SOLO

KOD [CODE]: T.OB.410

21.00 TL

KOMATSU
KOMATSU

KOD [CODE]: T.OB.411

21.00 TL

TECO TİP AKILLI BAŐLIK // TECO EASY LOAD



3mm kalınlığında misina sarılabilir.

Easy to load 3.00 mm line

**OLEO-MAC / EFCO, KAWASAKI, MITSUBISHI,
HONDA, HITACHI KNC, SECHO, ORAC, PALMERA,
BACO, FARMATE, FARMER, ENERGY VE DİĐER
PRC ÜRETİMİ TIRPANLARA UYUMLU MODEL**

EFCO, PRC BRUSHCUTTERS

KOD [CODE]: T.OB.601

25.00 TL

**ALPINA / CASTOR, OLEO - MAC / EFCO ESKİ MODEL
(8 MM, TERS DİŐ CİVATA ERKEK)**

ALPINA, EFCO OLD MODELS (8 MM BOLT)

KOD [CODE]: T.OB.602

25.00 TL

STIHL YAN MODEL 40/2, FS
STIHL STRAIGHT SHAFT MODEL

KOD [CODE]: T.OB.603

25.00 TL

STIHL SIRT MODEL 30/2, FR
STIHL FLEXIBLE SHAFT MODEL

KOD [CODE]: T.OB.604

25.00 TL

HQ, JONSEREDS YAN - SIRT
HQ, BOTH SHAFT MODELS

KOD [CODE]: T.OB.605

25.00 TL

DOLMAR
DOLMAR

KOD [CODE]: T.OB.606

25.00 TL

MITSUBISHI - KAAZ
MITSUBISHI - KAAZ

KOD [CODE]: T.OB.607

25.00 TL

SHINDAIWA YAN
SHINDAIWA, STRAIGHT SHAFT MODEL

KOD [CODE]: T.OB.608

25.00 TL

SHINDAIWA SIRT
SHINDAIWA, FLEXIBLE SHAFT MODEL

KOD [CODE]: T.OB.609

25.00 TL

SOLO
SOLO

KOD [CODE]: T.OB.610

25.00 TL

KOMATSU
KOMATSU

KOD [CODE]: T.OB.611

25.00 TL

AKILLI BAŞLIK // EASY LOAD



3.3 mm. Misina rahatlıkla sarılabilir.
Tüm yedek parçaları stoklarımızdadır.
Özel malzemesiyle zorlu kesim şartlarına uygundur.

Easy to load 3.3 mm line
It is suitable for heavy duty gardening with its strong material.

Her hangi bir sökme takma işlemi olmadan misina dışarıdan sokulup ortalanır.

No need to demontage for filling line



Makarasını çevirerek misina sarma işlemi tamamlanır.

You can fill the line by only rotating the reel.



OLEO-MAC / EFCO, KAWASAKI, MITSUBISHI, HONDA, HITACHI KNC, SECHO, ORAC, PALMERA, BACO, FARMATE, FARMER, ENERGY VE DİĞER PRC ÜRETİMİ TIRPANLARA UYUMLU MODEL

EFCO, PRC BRUSHCUTTERS

KOD [CODE]: **T.OB.301**

28.00 TL

ALPINA / CASTOR, OLEO - MAC / EFCO ESKİ MODEL (8 MM, TERS DİŞ CİVATA ERKEK)

ALPINA, EFCO OLD MODELS (8 MM BOLT)

KOD [CODE]: **T.OB.302**

28.00 TL

STIHL YAN MODEL 40/2, FS
STIHL STRAIGHT SHAFT MODEL

KOD [CODE]: **T.OB.303**

28.00 TL

STIHL SIRT MODEL 30/2, FR
STIHL FLEXIBLE SHAFT MODEL

KOD [CODE]: **T.OB.304**

28.00 TL

HQ, JONSEREDS YAN - SIRT
HQ, BOTH SHAFT MODELS

KOD [CODE]: **T.OB.305**

28.00 TL

DOLMAR
DOLMAR

KOD [CODE]: **T.OB.306**

28.00 TL

MITSUBISHI - KAAZ
MITSUBISHI - KAAZ

KOD [CODE]: **T.OB.307**

28.00 TL

SHINDAIWA YAN
SHINDAIWA, STRAIGHT SHAFT MODEL

KOD [CODE]: **T.OB.308**

28.00 TL

SHINDAIWA SIRT
SHINDAIWA, FLEXIBLE SHAFT MODEL

KOD [CODE]: **T.OB.309**

28.00 TL

SOLO
SOLO

KOD [CODE]: **T.OB.310**

28.00 TL

ÖRÜMCEK TİP BAŞLIKLAR // WHIPS TRIMMER HEADS



Kadiođlu İşçiliđi

Kadiođlu Malzemesi

Kolay Kullanım...

Kadmec Alüminyum Misina Başlıđı Ailesi



SIKMATİK AHTAPOT BAŞLIK (ÜNİVERSAL)
WHIPS TRIMMER HEAD (SUPER CUT 3)

KOD [CODE]: T.ORB.005

35.00 TL

Park, bahçe, golf sahası gibi alanlarda "sıfır kesim" için idealdir.
Tüm marka ve model benzin motorlu tırpanlara uyumludur.

It is ideal for parks, gardens and golf ranges where needs lowest cut.
Compatible for all brushcutters.

ÖRÜMCEK TİP BAŞLIKLAR // WHIPS TRIMMER HEADS



METAL MANTAR TIRPAN BAŞLIĞI (ÜNİVERSAL)
WHIPS TRIMMER HEAD SUPER CUT 2 (FOR ALL TYPES)

KOD [CODE]: T.ORB.001

27.00 TL

2-4 Parça misina takılabilir.
Taşlık alanlarda aşınma süresi uzundur.
Tüm marka ve model benzin motorlu tırpanlara uyumludur.

Suitable for 2 or 4 lines.
Abrasion life is longer in stany places.
Compatible for all brushcutters.



AHTAPOT BAŞLIĞI
TRIMMER HEAD

KOD [CODE]: T.ORB.101 (Standart)

KOD [CODE]: T.ORB.102 (Stihl Yan)

KOD [CODE]: T.ORB.103 (Stihl Sırt)

KOD [CODE]: T.ORB.104 (HQ)

16.00 TL

Park, bahçe, golf sahası gibi alanlarda "sıfır kesim" için idealdir.
Tüm marka ve model benzin motorlu tırpanlara uyumludur.

It is ideal for parks, gardens and golf ranges where needs lomest cut.
Compatible for all brushcutters.

ÖRÜMCEK TİP BAŞLIKLAR // WHIPS TRIMMER HEADS



AHTAPOT BAŞLIK (ÜNİVERSAL)

WHIPS TRIMMER HEAD SUPER CUT 1 (ONE SCREWED)

KOD [CODE]: **T.ORB.004**

18.00 TL

2-4 Parça misina takılabilir.
Taşlık alanlarda aşınma süresi uzundur.
Tek civata ile misina sabitlenir.
Tüm marka ve model benzin motorlu tırpanlara uyumludur.

Suitable for 2 or 4 lines.
Abrasion life is longer in stany places.
Can be fixed by only one screw.
Can be fixed by only one screw.



PLASTİK MANTAR BAŞLIK (ÜNİVERSAL)

WHIPS POLYMER

KOD [CODE]: **T.ORB.002**

15.00 TL

2-4 Parça misina takılabilir.
Kırılmaya karşı garantilidir.
Civata gerektirmeksizin misina sabitlenir.

Suitable for 2 or 4 lines.
Guaranteed to break off.
Can be fixed without any screw.
Can be fixed by only one screw.

ÖRÜMCEK TİP BAŐLİKLAR // WHIPS TRIMMER HEADS



AHTAPOT BİLYALI (ÜNİVERSAL)

WHIPS TRIMMER HEAD (ALUMINIUM, WITH BEARING)

KOD [CODE]: **T.ORB.003**

49.00 TL

**(SİPARİŐ İLE İMALATI YAPILMAKTADIR.
MİNİMUM SİPARİŐ ADETİ : MİN:100)**

2-4 Parça misina takılabilir.
Zemine temas eden parçası gövdeden bağımsızdır.
Tüm marka ve model benzin motorlu tırpanlara uyumludur.

Suitable for 2 or 4 lines.
The part that touches ground is separated from
body by bearing.
Can be fixed by only one screw.

DİSK TİP BAŐLİKLAR // DISK TYPE TRIMMER HEADS

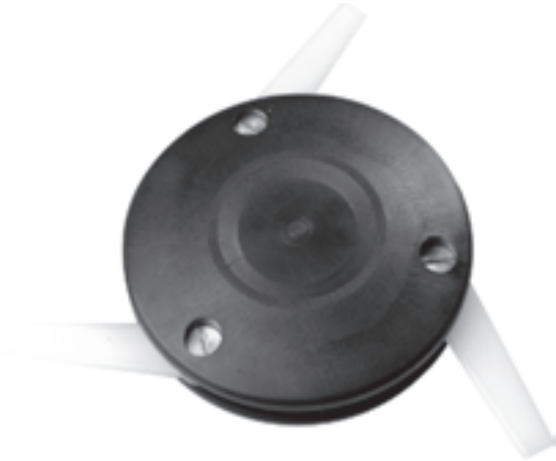

TRİCUT BAŐLİK

TRIM DISC

KOD [CODE]: **T.DB.001**

26.00 TL

Park, bahçe, golf sahası gibi alanlarda
Sıfır kesim için idealdir.

It is ideal for parks, gardens and golf ranges where
needs lomest cut.

DİSK TİP BAŞLIKLAR // DISK TYPE TRIMMER HEADS



METAL DİSK BAŞLIK (SET)

FOUR CUT HEAD ALUMINIUM

KOD [CODE]: T.DB.004

35.00 TL

Zorlu kesim şartlarında "sıfır kesim" için idealdir. Alüminyum gövdesi uzun süre yıpranmaz. 4 kesici bıçak ve 4 ayrı misina bağlanıp 12 kesim noktası oluşturulabilir. Bıçaksız, sadece misina ile kesim yapılabilir. Tüm marka ve model benzin motorlu tırpanlara uyumludur.

It is ideal for parks, gardens and golf ranges where needs lomest cut. Abrasion life is longer. You can make 12 cutting points by 4 plastic cutters and 4 lines. Also it can be used by only lines. Compatible for all brushcutters.

Parça misina "U" biçimi verilerek deliklerinden sokulur.



Çıkış deliğinden çıkartılarak gerilir.

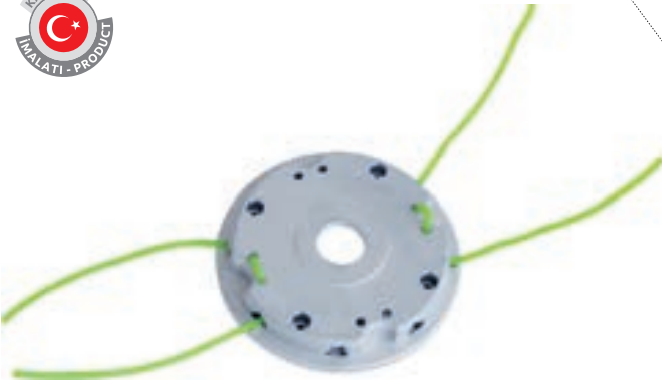

Kolay Misina Değişimi



METAL DİSK BAŞLIK (BIÇAKSIZ)

FOUR CUT DISC HEAD (WITHOUT KNIPE)

KOD [CODE]: T.DB.003

25.00 TL

Park, bahçe, golf sahası gibi alanlarda "sıfır kesim" için idealdir. 4 kesici bıçak ve 4 ayrı misina bağlanıp 12 kesim noktası oluşturulabilir. Bıçaksız, sadece misina ile kesim yapılabilir. Tüm marka ve model benzin motorlu tırpanlara uyumludur.

It is ideal for parks, gardens and golf ranges where needs lomest cut. You can make 12 cutting points by 4 plastic cutters and 4 lines. Also it can be used by only lines. Compatible for all brushcutters.

DİSK TİP BAŐLIKLAR // DISK TYPE TRIMMER HEADS



JETFİT 2'Lİ
EASY LOCK DISC DUAL

KOD [CODE]: T.DB.005

36.00 TL

Özel misinası, gövdeye özel kilitleme sistemi ile sabitlenir.
Zorlu kesim şartları için uygundur.
2 parça misina ile 2 kesim noktası oluşturulabilir.
Tüm marka ve model benzin motorlu tırpanlara uyumludur.

Line can be fixed easily by special lock system.
Suitable for 2 lines.
Compatible for all brushcutters.



JETFİT 4'LÜ
EASY LOCK DISC DUAL

KOD [CODE]: T.DB.006

49.00 TL

Özel misinası, gövdeye özel kilitleme sistemi ile sabitlenir.
4 parça misina ile 4 kesim noktası oluşturulabilir.
Tüm marka ve model benzin motorlu tırpanlara uyumludur.

Line can be fixed easily by special lock system.
Suitable for 4 lines.
Compatible for all brushcutters.

TIRPAN BIÇAKLARI // TRIMMER BLADES

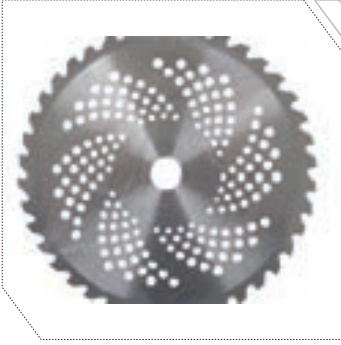

**ELMASLI
TESTERE**

40 T BLADE (WITH
DIAMONDS)

KOD [CODE]: T.PRC.054



26.00 TL



**BIÇAK
ÇELİK 2'Lİ**

BLADE
(STEEL, 2T)

KOD [CODE]: T.BCK.001



12.00 TL



**BIÇAK
ÇELİK 3'LÜ**

BLADE
(STEEL, 3T)

KOD [CODE]: T.BCK.002



18.00 TL



**BIÇAK
ÇELİK 4'LÜ**

BLADE
(STEEL, 4T)

KOD [CODE]: T.BCK.003



24.00 TL



**BIÇAK
PLASTİK 2'Lİ**

BLADE
(PLASTIC, 2T)

KOD [CODE]: T.BCK.004



11.00 TL



**BIÇAK
ÇELİK 2'Lİ 40 CM**

BLADE
(STEEL, 2T) 40CM

KOD [CODE]: T.BCK.006



13.00 TL



**BIÇAK
PLASTİK 3'LÜ**

BLADE
(PLASTIC, 4T)

KOD [CODE]: T.BCK.007



19.00 TL

CANAVAR BAŞLIK // KADMEC MONSTER TRIMMER HEAD

Korkutucu İşler için Şaşırtıcı Kesim Yeteneği...

Zincirler zincir başına 2 çelik pimle alüminyum gövdeye tutturulmuştur. Zincirde kopma dahi olsa zincirin her bir bölümü ayrı bir biçimde bağlı olduğu pimle gövdeye bağlı kalacak ve zincirden asla parça fırlatmayacaktır. Zincir koltuğunda balansa sebep olacağından koptuğu anda anlaşılır ve anında müdahale edilir.

- Tüm Tırpan modelleri ile uyumludur
- Suitable for all trimmers
- %80 daha fazla kesme gücü
- %80 More cutting power
- OREGON zincir kullanılmıştır
- With OREGON chain

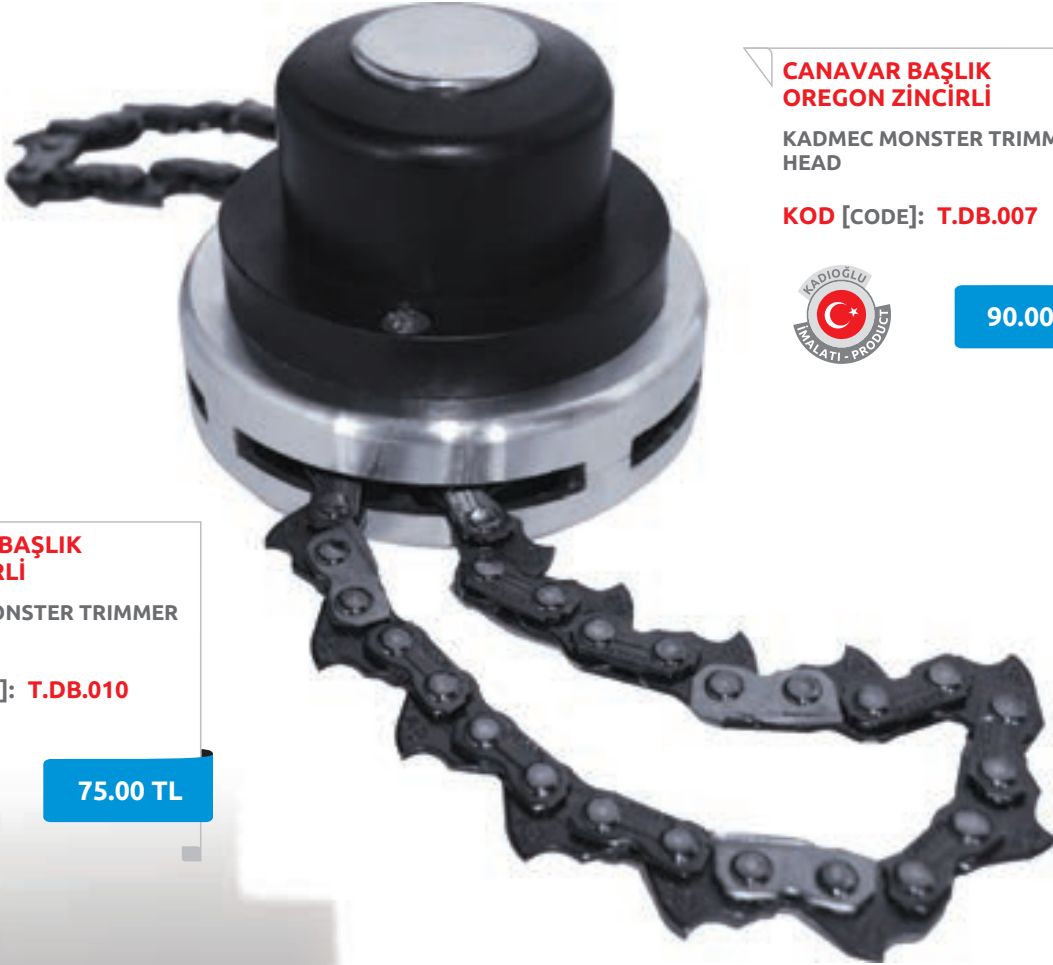

**CANAVAR BAŞLIK
OREGON ZİNCİRLİ**

KADMEC MONSTER TRIMMER
HEAD

KOD [CODE]: T.DB.007



90.00 TL

**CANAVAR BAŞLIK
PRC ZİNCİRLİ**

KADMEC MONSTER TRIMMER
HEAD

KOD [CODE]: T.DB.010

75.00 TL



**ZİNCİRLİ BAŞLIK
4'LÜ**

WITH STANDART CHAIN
HEAD QUAD

KOD [CODE]: T.DB.008



55.00 TL



**ZİNCİRLİ BAŞLIK
2'Lİ**

WITH STANDART CHAIN
HEAD DUAL

KOD [CODE]: T.DB.009



51.00 TL

TERMINATÖR BAŞLIK // TERMINATOR TRIMMER HEAD

En zor kesim şartlarında hızlı ve etkili kesim sağlar.
Sabit bıçaklı motorlu tırpan bıçaklarına göre %60 daha uzun
ömürlüdür ve darbe anında motoru korur.

TERMINATÖR BAŞLIK

TERMINATOR TRIMMER
HEAD

KOD [CODE]: T.DB.011



80.00 TL



BAŞLIK YEDEK PARÇALARI // TRIMMER HEADS SPARE PARTS



**AKILLI BAŞLIK
MAKARASI**

EASY LOAD HEAD
SPOOL

KOD [CODE]: T.OBY.012



8.10 TL



**AKILLI BAŞLIK
YAYI**

EASY LOAD HEAD
SPRING

KOD [CODE]: T.OBY.043



1.80 TL



**AKILLI BAŞLIK
KAPAĞI**

EASY LOAD HEAD
GUIDE TOP COVER

KOD [CODE]: T.OBY.044



5.00 TL



**AKILLI BAŞLIK
BURCU**

EASY LOAD HEAD
GUIDE EYELET

KOD [CODE]: T.OBY.045



2.40 TL



**AKILLI BAŞLIK
GÖVDESİ**

EASY LOAD HEAD
GUIDE FRAME

KOD [CODE]: T.OBY.046



16.00 TL



**AKILLI BAŞLIK
TAMİR TAKIMI**

(EASYLOAD) REPAIR KIT

KOD [CODE]: T.OBY.054



12.60 TL



**BÜYÜK TİP BAŞLIK
MAKARASI (STIHL)**

TAP N CUT BOSS TRIMMER
HEAD SPOOL (STIHL)

KOD [CODE]: T.OBY.004



6.00 TL



**BÜYÜK TİP BAŞLIK
KAPAĞI (STIHL)**

TAP N CUT BOSS HEAD
TRIMMER HEAD TOP COVER
(STIHL)

KOD [CODE]: T.OBY.009



6.00 TL



**BÜYÜK TİP BAŞLIK BURCU
(STIHL)**

TAP N CUT BOSS EYELET
(STIHL)

KOD [CODE]: T.OBY.017



1.90 TL



**BÜYÜK BAŞLIK TAMİR
TAKIMI**

TAP N CUT BOSS REPAIRKIT

KOD [CODE]: T.OBY.052



11.60 TL

BAŞLIK YEDEK PARÇALARI // TRIMMER HEADS SPARE PARTS

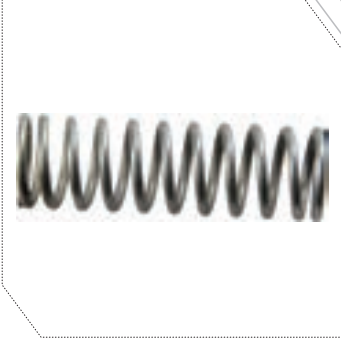

**BÜYÜK TİP BAŞLIK
YAYI (STIHL)**

TAP N CUT BOSS SPRING
(STIHL)

KOD [CODE]: T.OBY.030



1.30 TL



**BİLYALI BAŞLIK BİLYALI
GÖBEK**

WITH BEARING COMP

KOD [CODE]: T.OBY.036



20.00 TL



**BİLYALI BAŞLIK
KAPAK**

TRIMMER HEAD WITH
BEARING TOP COVER

KOD [CODE]: T.OBY.038



11.00 TL



**BİLYALI BAŞLIK
GÖVDE**

TRIMMER HEAD WITH
BEARING FRAME

KOD [CODE]: T.OBY.037



11.00 TL



**BİLYALI BAŞLIK
MAKARA**

TRIMMER HEAD WITH
BEARING SPOOL

KOD [CODE]: T.OBY.039



13.00 TL



**BİLYALI BAŞLIK
YAY**

TRIMMER HEAD WITH
BEARING SPRING

KOD [CODE]: T.OBY.040



2.00 TL



**BİLYALI BAŞLIK ALT
KAPAĞI**

TRIMMER HEAD WITH
BEARING PART

KOD [CODE]: T.OBY.055



7.00 TL



**CANAVAR BAŞLIK GÖVDESİ
PİMLİ SET**

MONSTERHEAD
FRAME

KOD [CODE]: T.OBY.010



34.00 TL



**CANAVAR BAŞLIK
YÜKSELTİCİSİ**

MONSTER HEAD
SPARE PART

KOD [CODE]: T.OBY.042



8.20 TL



**CANAVAR BAŞLIK
ARA PULU**

MONSTER HEAD
METAL RING

KOD [CODE]: T.OBY.011



6.20 TL

BAŞLIK YEDEK PARÇALARI // TRIMMER HEADS SPARE PARTS



**FOURCUT BAŞLIK BİÇAĞI
4'LÜ TAKIM**

TRIMMER HEAD
BLADE SET

KOD [CODE]: **T.OBY.055**



5.80 TL



**JETFİT ALT
KAPAK**

JETFIT COVER
(BOTTOM)

KOD [CODE]: **T.OBY.006**



6.50 TL



**KOLAY SARIM BAŞLIK
MAKARASI TECOMEC TİPİ**

TECOMEC TYPE TRIMMER
HEAD SPOOL (NEW MODEL)

KOD [CODE]: **T.OBY.003**



10.00 TL



**OTOMATİK BAŞLIK BURCU
HQ (BİLYALI)**

TAP N CUT WITH BEARING
TRIMMER HEAD EYELET (HQ)

KOD [CODE]: **T.OBY.014**



2.20 TL



**OTOMATİK BAŞLIK BURCU
KANALLI BÜYÜK**

TRIMMER HEAD EYELET
(BIG)

KOD [CODE]: **T.OBY.015**



2.30 TL



**KADMEC SARMALI BAŞLIK
BURCU**

EASY LOAD WITH GUIDE
(SMALL)

KOD [CODE]: **T.OBY.016**



2.30 TL



**ÖRÜMCEK BAŞLIK
PUL SETİ**

WHIPS TRIMMER HEAD
RING SET

KOD [CODE]: **T.OBY.041**



4.00 TL



**PLASTİK ÖRÜMCEK
ALT KAPAĞI**

WHIPS POLYMER
PART

KOD [CODE]: **T.OBY.047**



6.40 TL



**PLASTİK ÖRÜMCEK
ARA KAPAĞI**

WHIPS POLYMER
PART

KOD [CODE]: **T.OBY.048**



4.20 TL



**PLASTİK ÖRÜMCEK BASKI
PULU**

WHIPS POLYMER
RING

KOD [CODE]: **T.OBY.049**



1.20 TL

BAŞLIK YEDEK PARÇALARI // TRIMMER HEADS SPARE PARTS



**PLASTİK ÖRÜMCEK
ÜST GÖVDESİ**

WHIPS POLYMER
PART

KOD [CODE]: T.OBY.051



6.80 TL



**SARMALI TİP BAŞLIK
GÖVDESİ**

TRIMMER HEAD FRAME
(EASY LOAD WITH GUIDE)

KOD [CODE]: T.OBY.032



13.00 TL



**SARMALI TİP BAŞLIK
KAPAK ve MAKARA**

REPAIR KIT ((EASY LOAD WITH
GUIDE)

KOD [CODE]: T.OBY.033



8.50 TL



**SARMALI BAŞLIK
MAKARASI**

EASY LOAD WITH GUIDE
SPOOL

KOD [CODE]: T.OBY.053



5.00 TL



**SARMALI TİP BAŞLIK
YAYI**

SPRING
(EASY LOAD WITH GUIDE)

KOD [CODE]: T.OBY.035



1.80 TL



**SARMALI TİP BAŞLIK
MİSİNA KALEMİ**

GUIDE OF LINE

KOD [CODE]: T.OBY.034



2.00 TL



**STANDART TİP BAŞLIK
TAMİR TAKIMI**

TAP N CUT TRIMMER
HEAD REPAIR KIT

KOD [CODE]: T.OBY.001



5.90 TL



**STANDART TİP BAŞLIK
MAKARASI**

TAP N CUT TRIMMER
HEAD SPOOL

KOD [CODE]: T.OBY.002



2.90 TL



**STANDART TİP BAŞLIK
KAPAĞI ESKİ MODEL
(TIRNAKSIZ)**

TRIMMER HEAD TOP COVER
(OLD MODEL)

KOD [CODE]: T.OBY.008



2.90 TL



**STANDART TİP BAŞLIK
KAPAĞI YENİ MODEL**

TAP N CUT TRIMMER HEAD TOP
COVER (NEW MODEL)

KOD [CODE]: T.OBY.007



2.90 TL

BAŞLIK YEDEK PARÇALARI // TRIMMER HEADS SPARE PARTS



STANDART TİP BAŞLIK BURCU

TAP N CUT EYELET

KOD [CODE]: T.OBY.013



1.40 TL



STANDART TİP BAŞLIK SOMUNU ESKİ MODEL (ALPİNA)

TAP N CUT CLASSIC DRIVE BOLT (ALPİNA)

KOD [CODE]: T.OBY.018



5.20 TL



STANDART TİP BAŞLIK SOMUNU DOLMAR

TAP N CUT CLASSIC DRIVE NUT (DOLMAR)

KOD [CODE]: T.OBY.019



4.30 TL



STANDART TİP BAŞLIK SOMUNU HUSQVARNA

TAP N CUT CLASSIC DRIVE NUT (HQ)

KOD [CODE]: T.OBY.020



4.30 TL



STANDART TİP BAŞLIK SOMUNU KAAZ

TAP N CUT CLASSIC DRIVE NUT (KAAZ)

KOD [CODE]: T.OBY.021



4.30 TL



STANDART TİP BAŞLIK SOMUNU SHINDAWIA 8 mm

TAP N CUT CLASSIC DRIVE BOLT (SHINDAIWA, 8 mm)

KOD [CODE]: T.OBY.022



5.00 TL



STANDART TİP BAŞLIK SOMUNU SHINDAIWA 10 mm

TAP N CUT CLASSIC DRIVE BOLT (SHINDAIWA, 10 mm)

KOD [CODE]: T.OBY.023



5.00 TL



STANDART TİP BAŞLIK SOMUNU SOLO

TAP N CUT CLASSIC DRIVE NUT (SOLO)

KOD [CODE]: T.OBY.024



4.30 TL



STANDART TİP BAŞLIK SOMUNU STIHL SIRT

TAP N CUT CLASSIC DRIVE NUT (STIHL, FLEXIBLE SHAFT MODEL)

KOD [CODE]: T.OBY.025



4.30 TL



STANDART TİP BAŞLIK SOMUNU STIHL YAN

TAP N CUT CLASSIC DRIVE NUT (STIHL, STRAIGHT SHAFT MODEL)

KOD [CODE]: T.OBY.026



4.30 TL

BAŞLIK YEDEK PARÇALARI // TRIMMER HEADS SPARE PARTS

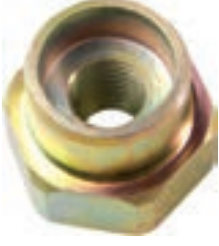

**STANDART TİP BAŞLIK
SOMUNU YENİ MODEL**

TAP N CUT CLASSIC DRIVE NUT
(NEW MODEL)

KOD [CODE]: T.OBY.027



4.00 TL



**STANDART TİP
BAŞLIK YAYI**

TAP N CUT CLASSIC
SPRING

KOD [CODE]: T.OBY.028



4.20 TL



**STANDART TİP BAŞLIK
YAYI PROFESYONEL**

TAP N CUT CLASSIC HEAD
SPRING (PROFESSIONAL)

KOD [CODE]: T.OBY.029



2.20 TL



**TRİCUT BAŞLIK BİÇAĞI
3'LÜ TAKIM**

TRIMMER HEAD
BLADE SET

KOD [CODE]: T.OBY.031



4.20 TL



**ZİNCİRLİ BAŞLIK
YEDEK ZİNCİRİ 2'Lİ**

WITH CHAIN HEAT
CHAIN

KOD [CODE]: T.OBY.050



12.00 TL



**CANAVAR BAŞLIK ZİNCİRİ
(OREGON 404)**

MONSTER HEAT
CHAIN

KOD [CODE]: T.OBY.005



28.00 TL



**TERMINATÖR BAŞLIK
YEDEK BİÇAĞI**

TERMINATOR TRIMMER
HEAD KNIFE

KOD [CODE]: T.OBY.055



7.00 TL

PROFESYONEL TİP MASKE // PROFESSIONAL TYPE MASK

*Makarası kusursuz çalışır.
Güneşte sertleşme, çatlama yapmaz.*



PROFESYONEL MASKE TELLİ
PROFESSIONAL MASK METAL NET SHIELD

KOD [CODE]: T.MSK.006

19.00 TL

PROFESYONEL TİP MASKE // PROFESSIONAL TYPE MASK



25.00 TL



*Özel malzemedan üretilmiştir.
Maskelerimiz yoğun güneş ışığına maruz
kalsa dahi formunu kaybetmez.*

PROFESYONEL MASKE YARIM CAMLI
PROFESSIONAL MASK METAL NET SHIELD

KOD [CODE]: T.MSK.003

25.00 TL

PROFESYONEL MASKE CAMLI
PROFESSIONAL MASK POLY CORBARADE SHIELD

KOD [CODE]: T.MSK.007

22.00 TL

GÜVENLİK MASKELERİ // PROTECTION MASKS



**YARI PROFESYONEL
TELLİ**
SEMI PROFESSIONAL MASK
METAL NET SHIELD

KOD [CODE]: T.MSK.001



8.50 TL



**YARI PROFESYONEL
CAMLİ**
SEMI PROFESSIONAL MASK
POLYCARBONATE SHIELD

KOD [CODE]: T.MSK.002



12.00 TL



**AMATÖR YARI
CAMLİ**
AMATEUR MASK SEMI
POLYCARBONATE SHIELD

KOD [CODE]: T.MSK.005



10.00 TL



**PROFESYONEL MASKE
YEDEK TELLİ**
METAL NET SHIELD FOR
PROF. MASK

KOD [CODE]: T.MSK.100



7.00 TL



**AMATÖR MASKE
YEDEK TELLİ**
METAL NET SHIELD FOR
AMATEUR MASK

KOD [CODE]: T.MSK.101



6.00 TL



**PROFESYONEL MASKE
YEDEK CAMI**
POLYCARBON SHIELD FOR
PROF. MASK

KOD [CODE]: T.MSK.102



8.00 TL



**AMATÖR MASKE
YEDEK CAMI**
POLYCARBON SHIELD FOR
AMATEUR MASK

KOD [CODE]: T.MSK.103



8.00 TL

TAŞIMA ASKILARI // HARNESES



ASKI SIRT OLEO-MAC/EFCO ESKİ MODEL

HARNESS (FOR FLEXIBLE SHAFT MODEL)

KOD [CODE]: T.ASK.001



28.00 TL



ASKI YAN OLEO-MAC/EFCO

HARNESS (FOR STRAIGHT SHAFT MODEL)

KOD [CODE]: T.ASK.002



18.00 TL



YAN ASKI 3 (PRC)

HARNESS (FOR STRAIGHT SHAFT MODEL) 3

KOD [CODE]: T.ASK.101



30.00 TL



YAN ASKI 2 (PRC)

HARNESS (FOR STRAIGHT SHAFT MODEL) 2

KOD [CODE]: T.ASK.103



32.00 TL



ÇİT BUDAMA MAKİNASI TAŞIMA ASKISI

HARNESS (FOR HEDGE CUTTER)

KOD [CODE]: T.ASK.102



250.00 TL



YAN ASKI 1 (PRC)

HARNESS (FOR STRAIGHT SHAFT MODEL)

KOD [CODE]: T.ASK.006



20.00 TL



SIRT ASKISI (PRC)

HARNESS (FOR FLEXIBLE SHAFT MODEL)

KOD [CODE]: T.ASK.005



58.00 TL



SIRT ASKISI İSKELETİ KOMPLE

HARNESS 2

KOD [CODE]: T.ASK.007



69.00 TL



ASKI SIRT STIHL

HARNESS (FOR FLEXIBLE SHAFT MODEL)

KOD [CODE]: T.ASK.003



90.00 TL



ASKI YAN STIHL

HARNESS (FOR STRAIGHT SHAFT MODEL)

KOD [CODE]: T.ASK.004



70.00 TL

AKSESUAR // ACCESSORIES



**PİLOT KOL UNIVERSAL
METAL KELEPÇELİ (STIHL)**
(26-28 mm)

HANDLE
UNIVERSAL

KOD [CODE]: T.AKS.010



17.00 TL



PİLOT KOL

LOOP HANDLE

KOD [CODE]: T.AKS.008



12.00 TL



**BENZİN
ÖLÇEĞİ**

FUEL & OIL MIXING
BOTTLE

KOD [CODE]: T.AKS.004



5.40 TL



KÖR BUJİ

PISTON STOP TOOL

KOD [CODE]: T.AKS.007



4.30 TL



MİSİNE KESME APARATI
26 - 28 mm

BLADE
(26 - 28 mm)

KOD [CODE]: T.AKS.009



10.00 TL



ALYEN ANAHTARI
4 mm

ALLEN KEY
(4 mm)

KOD [CODE]: T.AKS.001



7.50 TL



ALYEN ANAHTARI
4,5 mm

ALLEN KEY
(4,5 mm)

KOD [CODE]: T.AKS.002



7.50 TL



ALYEN ANAHTARI
5 mm

ALLEN KEY
(5 mm)

KOD [CODE]: T.AKS.003



7.50 TL



BUJİ ANAHTARI
13 - 19 mm

SCRENCH
(13 - 19 mm)

KOD [CODE]: T.AKS.005



3.60 TL



BUJİ ANAHTARI
17 - 19 mm





















SCRENCH
(17 - 19 mm)

KOD [CODE]: T.AKS.006



3.60 TL

ALPINA - CASTOR / CASTEL - GARDEN

	<p>ASKI YAYI HARNES SPRING</p> <p>KOD [CODE]: T.AC.003</p>  <p>1.60 TL</p>		<p>BALATA AĞIR CLUTCH (HEAVY)</p> <p>KOD [CODE]: T.AC.004</p>  <p>19.00 TL</p>
	<p>BALATA STANDART CLUTCH</p> <p>KOD [CODE]: T.AC.005</p>  <p>17.00 TL</p>		<p>BALATA CİVATASI CLUTCH BOLT</p> <p>KOD [CODE]: T.AC.006</p>  <p>2.50 TL</p>
	<p>BALATA TASI CLUTCH DRUM</p> <p>KOD [CODE]: T.AC.007</p>  <p>20.00 TL</p>		<p>BALATA YAYI KALIN CLUTCH SPRING (WIDE)</p> <p>KOD [CODE]: T.AC.008</p>  <p>1.30 TL</p>
	<p>BALATA YAYI STANDART CLUTCH SPRING</p> <p>KOD [CODE]: T.AC.009</p>  <p>1.30 TL</p>		<p>BENZİN HORTUM SETİ FUEL HOSE KIT</p> <p>KOD [CODE]: T.AC.067</p>  <p>6.70 TL</p>
	<p>BENZİN KAPAĞI FUEL FILLER CAP</p> <p>KOD [CODE]: T.AC.010</p>  <p>8.00 TL</p>		<p>BİÇAK CİVATASI KISA BLADE BOLT (SHORT TYPE)</p> <p>KOD [CODE]: T.AC.011</p>  <p>1.00 TL</p>

ALPINA - CASTOR / CASTEL - GARDEN



**BIÇAK CİVATASI
UZUN**

BLADE BOLT
(LONG TYPE)

KOD [CODE]: T.AC.012



1.00 TL



**BIÇAK
TASI**

RIDER
BLADE

KOD [CODE]: T.AC.013



11.00 TL



**BİSİKLET
KOL**

HANDLEBAR

KOD [CODE]: T.AC.066



30.00 TL



**BUJİ
BAŞLIĞI**

SPARK PLUG
BOOT

KOD [CODE]: T.AC.015



2.10 TL



BUJİ TELİ

TORSION
SPRING

KOD [CODE]: T.AC.016



0.90 TL



**DİŞLİ GRUBU KEÇE
BURCU**

GUARD
RING

KOD [CODE]: T.AC.014



3.50 TL



**DİYAFRAM
CONTASI**

DIAPHRAM
GASKET

KOD [CODE]: T.AC.017



2.20 TL



**DEPO
LASTİĞİ**

FUEL HOSE
GASKET

KOD [CODE]: T.AC.072



4.00 TL



**EGSOZ
BORUSU**

EXHAUST SHUTTER
COMP.

KOD [CODE]: T.AC.018



5.00 TL



SİLİNDİR

CYLINDER

KOD [CODE]: T.AC.103



140.00 TL

ALPINA - CASTOR / CASTEL - GARDEN



FREZELİ BIÇAK PULU ALT

THRUST PLATE (BOTTOM)

KOD [CODE]: T.AC.020



14.00 TL



FREZELİ BIÇAK PULU (ÜST)

THRUST PLATE (ABOVE)

KOD [CODE]: T.AC.021



8.00 TL



GAZ MİLİ

THROTTLE SHAFT

KOD [CODE]: T.AC.022



8.50 TL

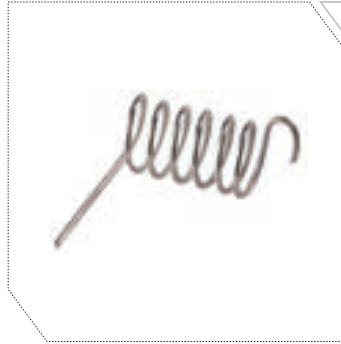

GAZ MİLİ YAYI

THROTTLE SPRING

KOD [CODE]: T.AC.023



1.00 TL

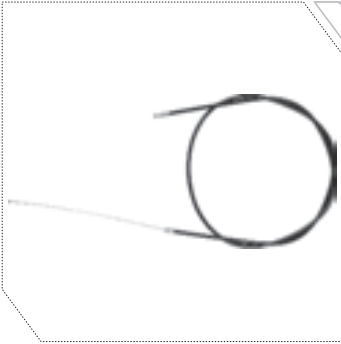

GAZ TELİ 55 SIRT

THROTTLE CABLE 55 (FOR FLEXIBLE SHAFT MODEL)

KOD [CODE]: T.AC.024



9.00 TL

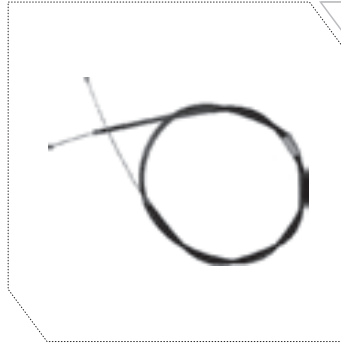

GAZ TELİ 55

THROTTLE CABLE (55)

KOD [CODE]: T.AC.025



9.00 TL

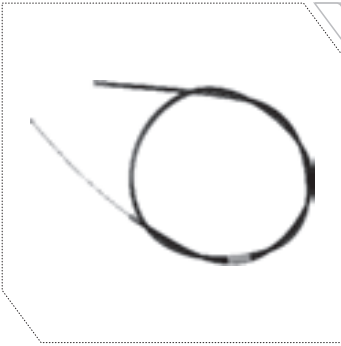

GAZ TELİ 52

THROTTLE CABLE (52)

KOD [CODE]: T.AC.026



9.00 TL

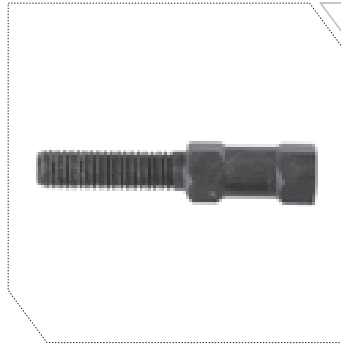

GAZ TELİ AYAR CİVATASI

THROTTLE LEVEL ADJUSTER

KOD [CODE]: T.AC.027



4.25 TL



GAZ TELİ EKLEME

THROTTLE CABLE COUPLER

KOD [CODE]: T.AC.028



10.00 TL



GAZ TELİ TUTUCU

THROTTLE CABLE CLAMP

KOD [CODE]: T.AC.029



2.30 TL

ALPINA - CASTOR / CASTEL - GARDEN



**GAZ TETİĞİ
ALT**

THROTTLE TRIGGER
(BOTTOM)

KOD [CODE]: T.AC.030



5.50 TL



**GAZ TETİK
YAYI**

THROTTLE TRIGGER
SPRING

KOD [CODE]: T.AC.031



1.20 TL



**HAVA
FİLTRESİ**

AIR
FILTER

KOD [CODE]: T.AC.071



3.10 TL



İP MAKARASI

STARTER PULLEY

KOD [CODE]: T.AC.032



6.25 TL



JİKLE LASTİĞİ

PRIMER BULB

KOD [CODE]: T.AC.033



2.20 TL



KRANK KECESİ

OIL SEAL

KOD [CODE]: T.AC.104



Bilgi Alınız



**KAFA SACI
BÜYÜK**

GUARD WASHER
(BIG TYPE)

KOD [CODE]: T.AC.034



2.20 TL



**KAFA SACI
KÜÇÜK**

GUARD WASHER
(SMALL TYPE)

KOD [CODE]: T.AC.035



2.20 TL



**DEPO KAPAK CONTASI
BÜYÜK**

FUEL CAP GASKET
(BIG)

KOD [CODE]: T.AC.101



1.50 TL

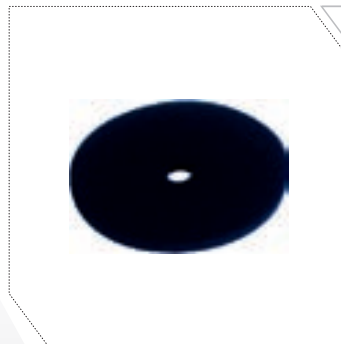

**DEPO KAPAK CONTASI
KÜÇÜK**

FUEL CAP GASKET
(BIG)

KOD [CODE]: T.AC.102



1.50 TL

ALPINA - CASTOR / CASTEL - GARDEN



MARŞ TIRNAK YAYI

STARTER PAWL SPRING

KOD [CODE]: T.AC.045



1.00 TL



KARBÜRATÖR SİBOBU

CARBURATOR VALVE COMP.

KOD [CODE]: T.AC.041



2.20 TL



KRANK KEÇESİ

CRANK OIL SEAL

KOD [CODE]: T.AC.042



5.00 TL



MARŞ KOVANI

STARTER PAWL CARRIER

KOD [CODE]: T.AC.043



24.00 TL



MARŞ TIRNAĞI

STARTER PAWL

KOD [CODE]: T.AC.044



2.30 TL



MARŞ KAPAK YAYI - 55

STARTER SPRING

KOD [CODE]: T.AC.069



3.00 TL



STARTER KAPAK BOŞ SARI

STARTER COVER (EMPTY, YELLOW)

KOD [CODE]: T.AC.054



25.00 TL



SİRAL HORTUM BAĞLANTI SOMUNU

RUBBER CONNECTOR FOR FLEXIBLE SHAFT

KOD [CODE]: T.AC.048



4.00 TL



STARTER KAPAK BOŞ GRİ

STARTER COVER (EMPTY, GREY)

KOD [CODE]: T.AC.053



25.00 TL



STARTER KAPAK BOŞ TURUNCU

STARTER COVER (EMPTY, ORANGE)

KOD [CODE]: T.AC.055



25.00 TL

ALPINA - CASTOR / CASTEL - GARDEN



**SPIRAL HORTUM
YUVASI (TAM SET)**

CLUTCH
HOUSING SET

KOD [CODE]: T.AC.056



80.00 TL



**SPIRAL HORTUM
YUVASI**

CLUTCH
HOUSING

KOD [CODE]: T.AC.050



40.00 TL



**SPIRAL YUVASI
SOMUNLU**

DRIVE SHAFT CONNECTOR
(WITH NUT)

KOD [CODE]: T.AC.052



8.00 TL



**SPIRAL YUVASI
VİDALI**

DRIVE SHAFT CONNECTOR
(WITH BOLT)

KOD [CODE]: T.AC.051



10.00 TL



**ÜST
TETİK**

TRIGGER
INTERLOCK

KOD [CODE]: T.AC.060



45.00 TL



**SPIRAL HORTUM
KİLİTLEME PİMİ**

FLEXIBLE SHAFT
LOCK PIN

KOD [CODE]: T.AC.049



45.00 TL



**STARTER KAPAK
DOLU GRİ**

STARTER COVER
(FULL, GREY)

KOD [CODE]: T.AC.057



45.00 TL



**STARTER KAPAK
DOLU SARI**

STARTER COVER
(FULL, YELLOW)

KOD [CODE]: T.AC.058



38.00 TL



**STARTER KAPAK DOLU
TURUNCU**

STARTER COVER (FULL,
ORANGE)

KOD [CODE]: T.AC.059



38.00 TL



**SÜNGER HAVA
FİLTRESİ**

AIR FILTER

KOD [CODE]: T.AC.068



2.40 TL

ALPINA - CASTOR / CASTEL - GARDEN



**ÜST TETİK
YAYI**

TRIGGER INTERLOCK
SPRING

KOD [CODE]: T.AC.061



1.00 TL



**YAĞ TAPA
CİVATASI**

OIL DRAIN
PLUG

KOD [CODE]: T.AC.062



1.20 TL



**YAĞ TAPA CİVATASI
GLASÖRLÜKLÜ**

GREASE NIPPLE

KOD [CODE]: T.AC.063



3.40 TL



**YAY
AMORTİSÖR**

VIBRATION ISOLATOR
(SPRING)

KOD [CODE]: T.AC.064



3.50 TL



**ZEMBEREK
REHBERİ**

REWIND SPRING
COMP.

KOD [CODE]: T.AC.065



2.40 TL



**KARBÜRATÖR
DİYAFRAMI**

CARBURATOR
DIAPHRAGM

KOD [CODE]: T.AC.040



2.20 TL



EGSOZ CONTASI

MUFFLER GASKET

KOD [CODE]: T.AC.105



5.50 TL



**KARBÜRATÖR KÜTÜK
CONTASI 2**

CARBURATOR GASKET 2
(OUTER)

KOD [CODE]: T.AC.107



1.00 TL



**KARB KÜTÜĞÜ CONTASI
52-55**

CARBURATOR GASKET
(INNER)

KOD [CODE]: T.AC.104



1.00 TL



KARBÜRATÖR CONTASI

CARBURATOR GASKET

KOD [CODE]: T.AC.109



1.00 TL

ALPINA - CASTOR / CASTEL - GARDEN



CONTA
CYLINDER GASKET

KOD [CODE]: T.AC.106



1.50 TL



**KARBÜRATÖR KÜTÜK
CONTASI 1**
CARBURATOR GASKET 1
(OUTER)

KOD [CODE]: T.AC.108



1.00 TL

DOLMAR



BALATA
CLUTCH

KOD [CODE]: T.DOL.003



50.00 TL



**BIÇAK
SOMUNU**
BLADE COLLAR
NUT

KOD [CODE]: T.DOL.001



4.80 TL

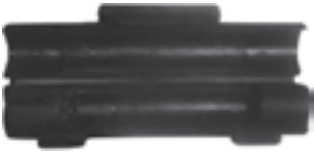





















**EKLEME
KABI**
COUPLER

KOD [CODE]: T.DOL.002



4.50 TL

HQ / JON

	<p>AMORTİSÖR VIBRATION ISOLATOR KOD [CODE]: T.HJ.001</p>  <p>3.00 TL</p>		<p>BALATA TASI (12 MM BİLYA GÖBEĞİ) CLUTCH DRUM (12 MM) KOD [CODE]: T.HJ.017</p>  <p>24.00 TL</p>
	<p>BIÇAK SOMUNU BLADE COLLAR NUT KOD [CODE]: T.HJ.002</p>  <p>4.80 TL</p>		<p>FREZELİ PUL 343R THRUST PLATE 343R KOD [CODE]: T.HJ.007</p>  <p>20.00 TL</p>
	<p>FREZELİ PUL 152RB THRUST PLATE 152RB KOD [CODE]: T.HJ.008</p>  <p>20.00 TL</p>		<p>FREZELİ KİLİTLEME PULU 152RB THRUST PLATE 152RB KOD [CODE]: T.HJ.009</p>  <p>22.00 TL</p>
	<p>FREZELİ PUL 153R THRUST PLATE 153R KOD [CODE]: T.HJ.010</p>  <p>24.00 TL</p>		<p>FREZELİ PUL 143R THRUST PLATE HUSQ 143R KOD [CODE]: T.HJ.011</p>  <p>20.00 TL</p>
	<p>GAZ TELİ SIRT KISA THROTTLE CABLE (SHORT) KOD [CODE]: T.HJ.014</p>  <p>10.00 TL</p>		<p>GAZ TELİ YAN 143-153 THROTTLE CABLE STRAIGHT SHAFT MODEL KOD [CODE]: T.HJ.015</p>  <p>9.80 TL</p>

HQ / JON



HUSQ 253 RB BALATA

CLUTCH 253 RB
(THINNER TYPE)

KOD [CODE]: T.HS.101



20.00 TL



**HUSQ 152 RB BALATA
(KALIN TİP)**

CLUTCH 152 RB
(WIDE TYPE)

KOD [CODE]: T.HS.102



20.00 TL



**GAZ TELİ SIRT (UZUN)
253 RB**

THROTTLE CABLE FLEXIBLE
SHAFT MODEL TONG TYPE

KOD [CODE]: T.HJ.016



9.80 TL



**MOTOR BAĞLANTI
SACI**

ENGINE MOUNT
PLATE

KOD [CODE]: T.HJ.003



20.00 TL



**SİRAL HORTUM
GİRİŞİ**

COUPLING
SLEEVE

KOD [CODE]: T.HJ.004



22.00 TL



**SPREL HORTUM KİLİTLEME
PİMİ (KISA)**

FLEXIBLE HOSE LOCK
PIN (SHORT)

KOD [CODE]: T.HJ.012



6.00 TL



**SPREL HORTUM KİLİTLEME
PİMİ (UZUN)**

FLEXIBLE HOSE LOCK
PIN (LONG)

KOD [CODE]: T.HJ.013



6.00 TL



**YAĞ TAPA
CİVATASI**

OIL DRAIN
PLUG

KOD [CODE]: T.HJ.005



3.40 TL



**YAĞ TAPA CİVATASI
GRASÖRLÜKLÜ**



















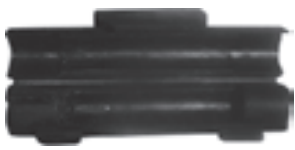

GREASE NIPPLE

KOD [CODE]: T.HJ.006























5.00 TL

KAWASAKI

	<p>AMORTİSÖR ALT VIBRATION ISOLATOR (BOTTOM) KOD [CODE]: T.MK.001</p> <p> 6.40 TL</p>		<p>AMORTİSÖR ALT 2 VIBRATION ISOLATOR 2 (BOTTOM) KOD [CODE]: T.MK.002</p> <p> 6.00 TL</p>
	<p>BALATA TASI SIRT CLUTCH DRUM (FOR FLEXIBLE SHAFT MODEL) KOD [CODE]: T.MK.003</p> <p> 24.00 TL</p>		<p>BALATA CLUTCH KOD [CODE]: T.MK.023</p> <p> 24.00 TL</p>
	<p>BENZİN DEPO KAPAĞI FUEL FILLER CAP KOD [CODE]: T.MK.004</p> <p> 8.00 TL</p>		<p>TAHLİYE SİBOBU VALVE COMP. KOD [CODE]: T.MK.005</p> <p> 2.00 TL</p>
	<p>EKLEME KABI COUPLER KOD [CODE]: T.MK.006</p> <p> 4.50 TL</p>		<p>KAWASAKI GAZ TELİ KISA 3 THNIST CABLE (SHART) KOD [CODE]: T.MK.101</p> <p> 15.00 TL</p>
	<p>KISA GAZ TELİ (230 mm) THROTTLE CABLE 1 (230 mm) KOD [CODE]: T.MK.026</p> <p> 16.00 TL</p>		<p>GAZ TELİ 2 THROTTLE CABLE 2 KOD [CODE]: T.MK.027</p> <p> 18.00 TL</p>

KAWASAKI

	<p>İP MAKARASI STARTER PULLEY KOD [CODE]: T.MK.008</p> <p> 10.00 TL</p>		<p>İP MAKARASI TIRNAĞI STARTER PULLEY PAWL KOD [CODE]: T.MK.009</p> <p> 5.00 TL</p>
	<p>İP MAKARASI SET STARTER PULLEY KOD [CODE]: T.MK.017</p> <p> 18.00 TL</p>		<p>İP ÇEKME SAPI STARTER GRIP KOD [CODE]: T.MK.020</p> <p> 2.60 TL</p>
	<p>KAFA SACI GUARD WASHER KOD [CODE]: T.MK.011</p> <p> 2.40 TL</p>		<p>MOTOR BAĞLANTI SACI BİLYALI ENGINE MOUNT PLATE (WITH BEARING) KOD [CODE]: T.MK.013</p> <p> 20.00 TL</p>
	<p>MOTOR BAĞLANTI ENGINE MOUNT PLATE KOD [CODE]: T.MK.014</p> <p> 18.00 TL</p>		<p>MOTOR BAĞLANTI SACI AMORTİSÖRLÜ ENGINE MOUNT PLATE (WITH VIBRATION ISOLATOR) KOD [CODE]: T.MK.015</p> <p> 30.00 TL</p>
	<p>MOTOR BAĞLANTI SACI YAYLI ENGINE MOUNT PLATE (WITH SPRING) KOD [CODE]: T.MK.028</p> <p> 30.00 TL</p>		<p>KAWASAKI ALT AYAK ENGINE MOUNT PLATE KAWASAKI KOD [CODE]: T.MK.102</p> <p> 32.00 TL</p>

KAWASAKI



SÜNGER HAVA FİLTRESİ-2

AIR FILTER - 2

KOD [CODE]: T.MK.019



2.20 TL



SÜNGER HAVA FİLTRESİ-1

AIR FILTER - 1

KOD [CODE]: T.MK.018



1.10 TL



STARTER DOLU

STARTER FULL

KOD [CODE]: T.MK.021



60.00 TL



TIRNAK YAYI

STARTER PAWL

KOD [CODE]: T.MK.016



1.80 TL

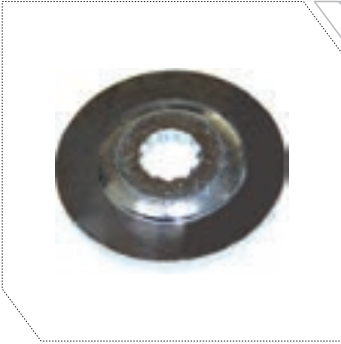

FREZELİ BIÇAK PULU

THRUST PLATE

KOD [CODE]: T.MK.025



13.00 TL



STARTER KAPAĞI

STARTER COVER

KOD [CODE]: T.MK.022



30.00 TL

KNC



BALATA

CLUTCH

KOD [CODE]: T.KNC.021



18.00 TL



BALATA TASI

CLUTCH DRUM

KOD [CODE]: T.KNC.002



18.00 TL



YAĞ CİVATASI

OIL DRAIN PLUG

KOD [CODE]: T.KNC.001



1.00 TL



KİLİTLEME PULU

THRUST PLATE
(LOCK PLATE)

KOD [CODE]: T.KNC.005



20.00 TL



ALT SAC AYAK

ENGINE MANT
PLATE

KOD [CODE]: T.KNC.003



20.00 TL

OLEO - MAC / EFCO / ERGO

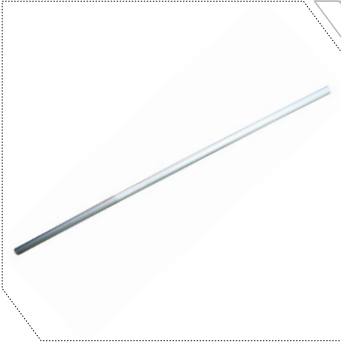

**ALÜMİNYUM
BORU (YAN)**

ALUMINIUM
PIPE

KOD [CODE]: T.OE.103



96.00 TL



**AMORTİSÖR
ALT**

VIBRATION ISOLATOR
(BOTTOM)

KOD [CODE]: T.OE.001



5.00 TL



**AMORTİSÖR BORU
BAĞLANTI KÖRÜĞÜ**

VIBRATION ISOLATOR
(RUBBER INSERT)

KOD [CODE]: T.OE.002



7.00 TL



**AMORTİSÖR
KANALLI**

VIBRATION ISOLATOR
(GROOVED)

KOD [CODE]: T.OE.003



2.70 TL



**AMORTİSÖR
MİNDER**

VIBRATION
ISOLATOR

KOD [CODE]: T.OE.004



4.20 TL



**AMORTİSÖR TAKOZU
YAN MODEL**

VIBRATION ISOLATOR
(FOR STRAIGHT SHAFT MODEL)

KOD [CODE]: T.OE.005



2.60 TL



**AMORTİSÖR
YAY**

VIBRATION ISOLATOR
(SPRING)

KOD [CODE]: T.OE.006



2.00 TL



**AMORTİSÖR YUVASI
BÜYÜK**

VIBRATION ISOLATOR PLATE
(BIG TYPE)

KOD [CODE]: T.OE.007



3.60 TL



**AMORTİSÖR YUVASI
KÜÇÜK**

VIBRATION ISOLATOR PLATE
(SMALL TYPE)

KOD [CODE]: T.OE.008



3.60 TL



**ASKI AYAR
PLASTİĞİ**

HARNES ADJUSTMENT
COMP.

KOD [CODE]: T.OE.009



4.00 TL

OLEO - MAC / EFCO / ERGO



ASKI KELEPÇESİ

HOSE CLAMP

KOD [CODE]: T.OE.010



8.00 TL



ASKI SIRT

HARNESS (FOR FLEXIBLE SHAFT MODEL)

KOD [CODE]: T.ASK.001



28.00 TL



ASKI YAN

HARNESS (FOR STRAIGHT SHAFT MODEL)

KOD [CODE]: T.ASK.002



18.00 TL



ASKI TOKASI ÜST

HARNESS CLIP (ABOVE)

KOD [CODE]: T.OE.013



4.00 TL



ASKI TOKASI ALT

HARNESS CLIP (BOTTOM)

KOD [CODE]: T.OE.014



4.00 TL



ASKI KİLİDİ

HARNESS LOCK

KOD [CODE]: T.OE.015



4.00 TL



ASKI YAYI YAN

HARNESS SPRING (FOR STRAIGHT SHAFT MODEL)

KOD [CODE]: T.OE.016



2.80 TL



BALATA

CLUTCH

KOD [CODE]: T.OE.017



19.00 TL



BALATA CİVATASI (YENİ MODEL) (ALYENLİ)

CLUTCH BOLT (NEW MODEL)

KOD [CODE]: T.OE.107



3.00 TL



BALATA CİVATASI

CLUTCH BOLT

KOD [CODE]: T.OE.018



2.10 TL

OLEO - MAC / EFCO / ERGO



BALATA TASI SIRT

CLUTH DRUM (FOR FLEXIBLE SHAFT MODEL)

KOD [CODE]: T.OE.019



20.00 TL



BALATA TASI YAN FREZELİ

CLUTCH DRUM (FOR STRAIGHT SHAFT MODEL)

KOD [CODE]: T.OE.020



25.00 TL



BENZİN DEPO KAPAĞI TAHLİYE SİBOPSUZ

FUEL FILLER COP WITHOUT VALVE COMPONENT

KOD [CODE]: T.OE.113



8.00 TL



OLEO MAC ERGO KAPAK CONTASI

FUEL CAP GASKET

KOD [CODE]: T.OE.201



1.50 TL



BENZİN DEPO KAPAĞI

FUEL FILLER CAP

KOD [CODE]: T.OE.022



8.00 TL



BENZİN HORTUMU

FUEL HOSE

KOD [CODE]: T.OE.023



3.60 TL



BENZİN TAHLİYE SİBOBU

FUEL FILLER CAP VALVE COMP.

KOD [CODE]: T.OE.024



2.00 TL

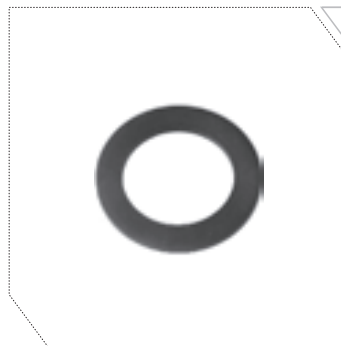

BENZİN KAPAK CONTASI

FUEL FILLER CAP GASKET

KOD [CODE]: T.OE.025



1.40 TL



BIÇAK CİVATASI KISA

BLADE BOLT (SHORT TYPE)

KOD [CODE]: T.AC.011



1.00 TL



BIÇAK CİVATASI UZUN

BLADE BOLT (LONG TYPE)

KOD [CODE]: T.OC.012



1.00 TL

OLEO - MAC / EFCO / ERGO



BIÇAK SOMUNU

BLADE COLLAR NUT

KOD [CODE]: T.OE.028



4.80



BIÇAK TASI (YENİ MODEL)

RIDER GUIDE (NEW MODEL)

KOD [CODE]: T.OE.095



5.60



BIÇAK TASI

RIDER GUIDE

KOD [CODE]: T.OE.029



4.80



BİLYALI TAS

GUARD RING

KOD [CODE]: T.OE.031



10.00



BİLYALI TAS YUVASI ÖZEL

GUARD RING (SPECIAL)

KOD [CODE]: T.OE.032



7.00



BUJİ BAŞLIĞI

SPARK PLUG BOOT

KOD [CODE]: T.OE.033



2.00



BUJİ TELİ

TORSION SPRING

KOD [CODE]: T.OE.034



0.90



ÇİFT VİDALI AMORTİSÖR

VIBRATION ISOLATOR

KOD [CODE]: T.OE.100



7.00



ÇEKME SAPI

STARTER HANDLE

KOD [CODE]: T.OE.035



2.60



DİŞLİ GRUBU KEÇE BURCU

OIL SEAL FOR GEARCASE

KOD [CODE]: T.OE.030



3.40

OLEO - MAC / EFCO / ERGO



**BALATA
YAYI**

CLUTCH
SPRING

KOD [CODE]: T.OE.021



1.40 TL



**EGSOZ PANCURU
GRİ**

MUFFLER COVER
(GREY)

KOD [CODE]: T.OE.037



20.00 TL



**EGSOZ PANCURU
TURUNCU**

MUFFLER COVER
(ORANGE)

KOD [CODE]: T.OE.038



20.00 TL



**EGSOZ PANCURU
KIRMIZI**

MUFFLER COVER
(ORANGE)

KOD [CODE]: T.OE.114



20.00 TL



FİLTRE

AIR FILTER

KOD [CODE]: T.OE.039



2.90 TL



FİLTRE KAPAĞI

AIR FILTER COVER

KOD [CODE]: T.OE.040



20.00 TL



FİLTRE KAPAĞI

AIR FILTER COVER

KOD [CODE]: T.OE.116



20.00 TL



**FİLTRE KAPAK
VİDASI**

AIR FILTER COVER
CAP

KOD [CODE]: T.OE.041



4.00 TL



**FİLTRE TUTUCU
KÜÇÜK**

AIR FILTER HOUSING
(SMALL TYPE)

KOD [CODE]: T.OE.042



4.00 TL

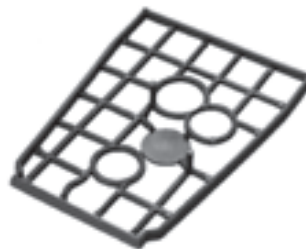

**FİLTRE TUTUCU
BÜYÜK**

AIR FILTER HOUSING
(BIG TYPE)

KOD [CODE]: T.OE.043



4.00 TL

OLEO - MAC / EFCO / ERGO



**FREZELİ PUL
ALT**

THRUST PLATE
(BOTTOM)

KOD [CODE]: T.OE.044



17.00 TL



**FREZELİ KİLİTLEME
PULU (YAN)**

THRUST PLATE OLEOMAC
(FOR STR. SHAFT MODEL)

KOD [CODE]: T.OE.109



25.00 TL



**FREZELİ KİLİTLEME
PULU (SIRT)**

THRUST PLATE (LOCK PLATE)
(WITH PLATE)

KOD [CODE]: T.OE.045



25.00 TL



**FREZELİ BIÇAK
PULU ÜST**

THRUST PLATE
(ABOVE)

KOD [CODE]: T.OE.046



8.50 TL



**FREZELİ BIÇAK PULU
(YAN TİP)**

THRUST PLATE
(STRAİPHT SHAFT MODEL)

KOD [CODE]: T.OE.202



9.00 TL



**FREZELİ BIÇAK
PULU (ESKİ MODEL)**

THRUST PLATE

KOD [CODE]: T.OE.046



8.00 TL



GAZ MİLİ

THROTTLE SHAFT

KOD [CODE]: T.OE.047



8.00 TL



GAZ MİLİ YAYI

THROTTLE SPRING

KOD [CODE]: T.OE.048



1.00 TL



**GAZ TELİ
163 mm**

THROTTLE TABLE
(163 mm)

KOD [CODE]: T.OE.049



7.50 TL



**GAZ TELİ
193 mm**

THROTTLE TABLE
(193 mm)

KOD [CODE]: T.OE.050



8.00 TL

OLEO - MAC / EFCO / ERGO



GAZ TELİ

THROTTLE CABLE

KOD [CODE]: T.OE.096



10.00 TL



GAZ TELİ ERGO

THROTTLE CABLE ERGO

KOD [CODE]: T.OE.106



10.00 TL

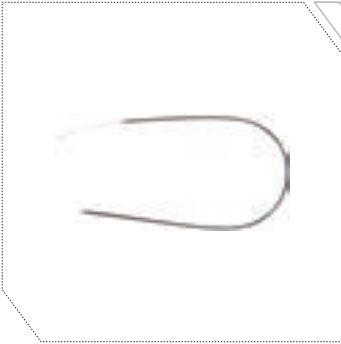

GAZ TELİ SIRT

THROTTLE CABLE (FOR FLEXIBLE SHAFT MODEL)

KOD [CODE]: T.OE.053



9.00 TL

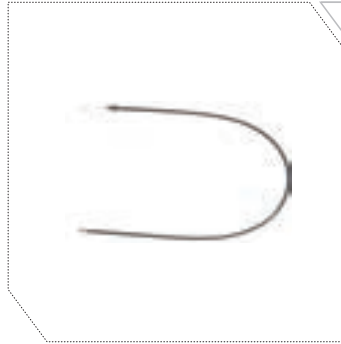

GAZ TELİ SIRT ERGO

THROTTLE CABLE (FOR ERGO MODEL)

KOD [CODE]: T.OE.054



10.00 TL

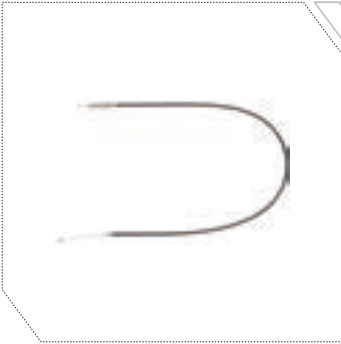

GAZ TELİ YAN MODEL

THROTTLE CABLE (FOR STRAIGHT SHAFT MODEL)

KOD [CODE]: T.OE.055



10.00 TL



GAZ TELİ TUTUCU

THROTTLE CABLE CLAMP

KOD [CODE]: T.AC.029



2.10 TL



GAZ TETİĞİ

THROTTLE TRIGGER

KOD [CODE]: T.OE.057



5.20 TL



GAZ TETİK YAYI

TRIGGER SPRING

KOD [CODE]: T.OE.058



1.00 TL



İP MAKARASI BÜYÜK

STARTER PULLEY (BIG TYPE)

KOD [CODE]: T.OE.059



5.20 TL



İP MAKARASI KÜÇÜK

STARTER PULLEY (SMALL TYPE)

KOD [CODE]: T.OE.060



4.60 TL

OLEO - MAC / EFCO / ERGO



JİKLE KOLU

CHOKE KNOB

KOD [CODE]: T.OE.061



4.00 TL



JİKLE SİBOBU

PRIMER BULB

KOD [CODE]: T.OE.062



2.20 TL

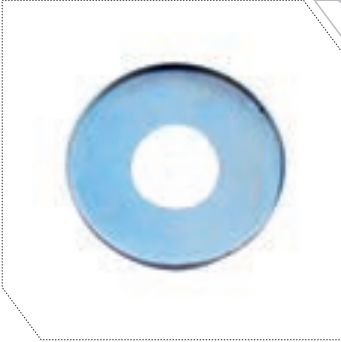

KAFA SACI KÜÇÜK

GUARD WASHER (SMALL TYPE)

KOD [CODE]: T.OE.101



2.20 TL



KAFA SACI ORTA

GUARD WASHER (MEDIUM TYPE)

KOD [CODE]: T.OE.102



2.20 TL



KARBÜRATÖR KÜTÜĞÜ

CARBURATOR COMP.

KOD [CODE]: T.OE.110



18.00 TL

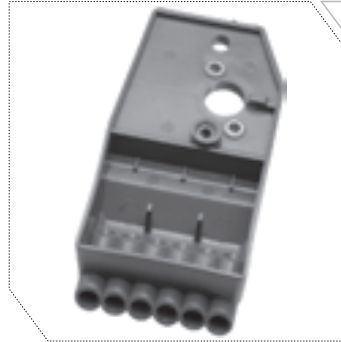

KARBÜRATÖR ADAPTÖRÜ

CARBURATOR ADAPTOR

KOD [CODE]: T.OE.063



18.00 TL

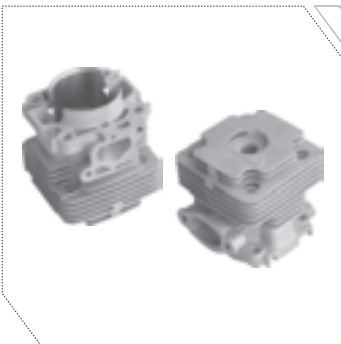

SİLİNDİR (453)

CYLINDER 453

KOD [CODE]: T.OE.203



140.00 TL



FREZELİ ARA PARÇA (SİRAL HORTUM ÇIKIŞDAKI)

DRIVE SHAFT CONNECTOR

KOD [CODE]: T.OE.204



28.00 TL



ALP KRANK KEÇESİ

OIL SEAL

KOD [CODE]: T.OE.205



Bilgi Alınız



KARBÜRATÖR SİBOBU

CARBURATOR COMP.

KOD [CODE]: T.OE.067



2.00 TL

OLEO - MAC / EFCO / ERGO



MARŞ TIRNAK YAYI

STARTER PAWL SPRING

KOD [CODE]: T.OE.075



1.40 TL



MARŞ TIRNAK YAYI ERGO

STARTER PAWL SPRING (FOR ERGO MODEL)

KOD [CODE]: T.OE.074



1.40 TL



MARŞ TIRNAĞI

STARTER PAWL

KOD [CODE]: T.OE.071



2.30 TL



MARŞ TIRNAĞI YAN MODEL

STARTER PAWL (FOR STRAIGHT SHAFT MODEL)

KOD [CODE]: T.OE.072



2.30 TL



MARŞ TIRNAĞI ERGO

STARTER PAWL (FOR ERGO MODEL)

KOD [CODE]: T.OE.073



2.00 TL



STOP ANAHTARI

ON / OFF SWITCH

KOD [CODE]: T.OE.086



4.00 TL



MARŞ KOVANI KOMPLE

STARTER PAWL SET

KOD [CODE]: T.OE.070



18.00 TL



MOTOR BAĞLANTI SACI ALT

ENGINE MOUNT PLATE

KOD [CODE]: T.OE.076



18.00 TL



GAZ TELİ EKİ

COUPLER COMP.

KOD [CODE]: T.OE.051



2.10 TL



GAZ TELİ EKLEME KABI (SET)

COUPLER

KOD [CODE]: T.OE.052



6.00 TL

OLEO - MAC / EFCO / ERGO



SÜNGER HAVA FİLTRESİ-1

AIR FILTER-1

KOD [CODE]: T.OE.097



2.00 TL



SÜNGER HAVA FİLTRESİ-2

AIR FILTER-2

KOD [CODE]: T.OE.098



2.00 TL



SÜNGER HAVA FİLTRESİ-3

AIR FILTER-3

KOD [CODE]: T.OE.099



2.00 TL



SİRAL HORTUM KİLİTLEME PİMİ KISA

FLEXIBLE SHAFT LOCK PIN (SHORT TYPE)

KOD [CODE]: T.OE.080



14.00 TL



SİRAL KİLİTLEME PİMİ

FLEXIBLE SHAFT LOCK PIN

KOD [CODE]: T.OE.104



14.00 TL



SİRAL HORTUM KİLİTLEME PİMİ UZUN

FLEXIBLE SHAFT LOCK PIN (LONG TYPE)

KOD [CODE]: T.OE.081



14.00 TL



SİRAL KİLİTLEME YAYI

FLEXIBLE SHAFT LOCK SPRING

KOD [CODE]: T.OE.082



1.60 TL



SİRAL MİL YUVASI

DRIVE SHAFT CONNECTOR

KOD [CODE]: T.OE.083



8.00 TL



STARTER KAPAK BOŞ (SARI BURÇLU)

STARTER COVER (EMPTY)

KOD [CODE]: T.OE.084



24.00 TL



STARTER KAPAK BOŞ (SARI BURÇLU)

STARTER COVER (EMPTY)

KOD [CODE]: T.OE.115



24.00 TL

OLEO - MAC / EFCO / ERGO



STARTER SET (SARI BURÇLU)

OLEOMAC STARTER SET

KOD [CODE]: T.OE.108



45.00 TL



STARTER SET (SARI BURÇLU)

OLEOMAC STARTER SET

KOD [CODE]: T.OE.111



45.00 TL



ÜST KAPORTA BUJİ KAPAĞI KIRMIZI

SPARK PLUG BOOT COVER (RED)

KOD [CODE]: T.OE.087



8.00 TL



ÜST KAPORTA KIRMIZI

SHROUD (RED)

KOD [CODE]: T.OE.088



20.00 TL



ÜST KAPORTA KOMPLE TURUNCU

SHROUD (SET, ORANGE)

KOD [CODE]: T.OE.089



25.00 TL



ÜST KAPORTA BUJİ KAPAĞI TURUNCU

SPARK PLUG BOOT COVER (ORANGE)

KOD [CODE]: T.OE.090



8.00 TL



YAĞ TAPA CİVATASI GRASÖRLÜKLÜ YENİ MODEL

GREASE NIPPLE (NEW MODEL)

KOD [CODE]: T.OE.091



3.00 TL



YAĞ TAPA CİVATASI GLASÖRLÜKLÜ ESKİ MODEL

GREASE NIPPLE (OLD MODEL)

KOD [CODE]: T.OE.092



3.00 TL



YAĞ TAPA CİVATASI YENİ MODEL

OIL DRAIN PLUG (NEW MODEL)

KOD [CODE]: T.OE.093



1.20 TL



YAĞ TAPA CİVATASI ESKİ MODEL





















OIL DRAIN PLUG (OLD MODEL)

KOD [CODE]: T.OE.094



1.20 TL

OLEO - MAC / EFCO / ERGO

	<p>KRANK KEÇESİ CRANK OIL SEAL KOD [CODE]: T.OE.069</p> <p> 4.00 TL</p>		<p>EGSOZ CONTASI EXHAUST GASGET KOD [CODE]: T.OE.036</p> <p> 2.60 TL</p>
	<p>SİLİNDİR CONTASI CYLINDER GASKET KOD [CODE]: T.OE.209</p> <p> 2.00 TL</p>		<p>ERGO KARB KÜTÜK CONTASI ERGO MUFFLER GASKET KOD [CODE]: T.OE.212</p> <p> 1.00 TL</p>
	<p>ERGO KARB CONTASI ERGO KARBURATOR GASKET INNER KOD [CODE]: T.OE.211</p> <p> 1.00 TL</p>		<p>ERGO EGSOZ CONTASI ERGO MUFFLER GASKET KOD [CODE]: T.OE.212</p> <p> 1.50 TL</p>
	<p>ERGO SİLİNDİR CONTASI ERGO CYLINDER GASKET KOD [CODE]: T.OE.205</p> <p> 2.00 TL</p>		<p>SİLİNDİR CONTASI CYLINDER GASKET KOD [CODE]: T.OE.206</p> <p> 2.00 TL</p>
	<p>EGSOZ CONTASI MUFFLER GASKET KOD [CODE]: T.OE.213</p> <p> 3.00 TL</p>		<p>KARBÜRATÖR DİYAFRAM CARBURATOR DIAPHRAGM KOD [CODE]: T.OE.064</p> <p> 2.60 TL</p>

OLEO - MAC / EFCO / ERGO



**SİLİNDİR CONTASI
YENİ MODEL**

CYLINDER GASKET
(NEW MODEL)

KOD [CODE]: T.OE.079



2.00 TL



**KARBÜRATÖR DİYAFRAM
CONTASI ALT**

CARBURATOR DIAPHRAGM
(BOTTOM)

KOD [CODE]: T.OE.065



2.20 TL



**KARTER
CONTASI**

CRANKCASE
GASKET

KOD [CODE]: T.OE.068



3.00 TL



**KOMPLE CONTA
TAKIMI**

GASKET SET

KOD [CODE]: T.OE.112



8.00 TL



KARB KÜTÜK CONTASI

CARBURATOR GASTER
(OUTER)

KOD [CODE]: T.OE.207



1.00 TL



KARB CONTASI











CARBURATOR GASTER
(OUTER)

KOD [CODE]: T.OE.208



1.00 TL

(P.R.C.) PALMERA / SECHO / ORAC / ENERGY / MITSUBISHI

	<p>BALATA CLUTCH KOD [CODE]: T.PRC.001 ITHAL IMPORTED 16.00 TL</p>		<p>BALATA 2 CLUTCH 2 KOD [CODE]: T.PRC.002 ITHAL IMPORTED 16.00 TL</p>
	<p>BALATA CİVATASI YERLİ ÜRETİM CLUTCH BOLT KOD [CODE]: T.PRC.003 KADIOĞLU İMALATI - PRODUCT 2.00 TL</p>		<p>BALATA KOVANI CLUTCH HOUSING KOD [CODE]: T.PRC.004 ITHAL IMPORTED 49.00 TL</p>
	<p>BAŞLIK SACI 3 DELİKLİ RIDER GUIDE KOD [CODE]: T.PRC.094 KADIOĞLU İMALATI - PRODUCT 4.240 TL</p>		<p>BALATA KOVANI YAN SET CLUTCH HOUSING (FOR STRAIGHT SHAFT MODEL) KOD [CODE]: T.PRC.006 ITHAL IMPORTED 54.00 TL</p>
	<p>BALATA KOVANI SIRT-2 CLUTCH HOUSING (FOR FLEXIBLE SHAFT MODEL-2) KOD [CODE]: T.PRC.050 ITHAL IMPORTED 50.00 TL</p>		<p>BALATA YAYI CLATCH SPRING KOD [CODE]: T.PRC.099 KADIOĞLU İMALATI - PRODUCT 1.40 TL</p>
	<p>SECHO KİLİTLEME PULU THRUST (LOCK) PLATE SECHO KOD [CODE]: T.PRC.209 KADIOĞLU İMALATI - PRODUCT 18.00 TL</p>		<p>SECHO BIÇAK PULU THRUST PLATE SECHO KOD [CODE]: T.PRC.208 KADIOĞLU İMALATI - PRODUCT 13.00 TL</p>

(P.R.C.) PALMERA / SECHO / ORAC / ENERGY / MITSUBISHI



PRC BALATA TASI 9 DİŞ

CLUTCH DRUM
(9 TEETH)

KOD [CODE]: T.PRC.064



20.00 TL



BALATA TASI YAN İTHAL

CLUTCH DRUM
(FOR STRAIGHT SHAFT MODEL)

KOD [CODE]: T.PRC.008



18.00 TL



BALATA TASI 7 DİŞ

CLUTCH DRUM
(7 TEETH)

KOD [CODE]: T.PRC.201



21.00 TL



ÇİFT BİLYALI İÇİN BALATA TASI

CLUTCH DRUM
(WITH 2 BEARING)

KOD [CODE]: T.PRC.203



21.00 TL



BENZİN MUSLUK ÇİVATASI SÜZGEÇLİ YERLİ ÜRETİM

FUEL TAP BOLT
(WOTH FILTER)

KOD [CODE]: T.PRC.011



6.00 TL



BIÇAK SOMUNU YERLİ ÜRETİM

BLADE COLLER NUT

KOD [CODE]: T.PRC.012



1.40 TL



BENZİN DEPO KAPAĞI-2

FUEL FILLER
CAP-2

KOD [CODE]: T.PRC.051



4.50 TL



BENZİN KAPAĞI SET

FUEL FILLER CAP SET

KOD [CODE]: T.PRC.010



4.50 TL



BENZİN DEPO KAPAĞI (ÜSTTEN KAPAKLI)

FUEL FILLER CAP 1

KOD [CODE]: T.PRC.092



4.50 TL



BENZİN DEPO KAPAĞI (YANDAN KAPAKLI)

FUEL FILLER CAP 1

KOD [CODE]: T.PRC.093



4.50 TL

(P.R.C.) PALMERA / SECHO / ORAC / ENERGY / MITSUBISHI



**BENZİN DEPO
HORTUMU SET**
FUEL HOSE KIT

KOD [CODE]: T.PRC.102



6.40 TL



**DEPO BENZİN ÇIKIŞ LASTİĞİ
(YERLİ ÜRETİM)**
FUEL TANK COMP.

KOD [CODE]: T.PRC.067



3.40 TL



**BENZİN DEPOSU
SET 3**
FUEL TANK 3

KOD [CODE]: T.PRC.095



22.00 TL



**BENZİN DEPOSU
ÜSTTEN DEPOLULAR İÇİN**
FUEL TANK

KOD [CODE]: T.PRC.097



19.50 TL



**BENZİN DEPOSU
SET 1**
FUEL TANK 1

KOD [CODE]: T.PRC.096



19.50 TL



**DİŞLİ GRUBU (KARE)
SIRT 26 mm (TAM SET)**
GEAR CASE 26 mm (FOR
FLEXIBLE SHAFT MODEL)

KOD [CODE]: T.PRC.052



68.00 TL



**DİŞLİ GRUBU YAN (FREZELİ)
26 mm (TAM SET)**
GEAR CASE (FOR STRAIGHT
SHAFT MODEL) 26 mm

KOD [CODE]: T.PRC.053



68.00 TL



**DİŞLİ GRUBU YAN
28 mm (TAM SET)**
GEAR CASE (FOR STRAIGHT
SHAFT MODEL) 28 mm

KOD [CODE]: T.PRC.069



68.00 TL



**DİŞLİ GRUBU SIRT
28 mm (TAM SET)**
GEAR CASE 28 mm (FOR
FLEXIBLE SHAFT MODEL)

KOD [CODE]: T.PRC.068



68.00 TL



**DİŞLİ GRUBU
KOMPLE (FREZELİ PULLU)**
GEAR CASE

KOD [CODE]: T.PRC.014



68.00 TL

(P.R.C.) PALMERA / SECHO / ORAC / ENERGY / MITSUBISHI



MUHAFAZA KAPAĞI

CARBURATOR COVER

KOD [CODE]: T.PRC.207



8.00 TL



BOBİN

IGNITION COIL

KOD [CODE]: T.PRC.013



25.00 TL



EGSOZ MUHAFAZA KAPAĞI

MUFFLER COVER

KOD [CODE]: T.PRC.015



8.00 TL



FREZELİ PUL YERLİ ÜRETİM

THRUST PLATE

KOD [CODE]: T.PRC.016



12.00 TL



GAZ TELİ SET-1

THROTTLE CABLE-1

KOD [CODE]: T.PRC.055



12.00 TL



GAZ TELİ SET-2

THROTTLE CABLE-2

KOD [CODE]: T.PRC.056



12.00 TL



GAZ TETİK YAYI SIRT (YERLİ ÜRETİM)

THROTTLE SPRING (FOR FLEXIBLE SHAFT MODEL)

KOD [CODE]: T.PRC.070



1.00 TL



GAZ TETİK YAYI YAN (YERLİ ÜRETİM)

THROTTLE SPRING (FOR STRAIGHT SHAFT MODEL)

KOD [CODE]: T.PRC.071



1.00 TL



GAZ TETİĞİ (YERLİ ÜRETİM)

THROTTLE TRIGGER

KOD [CODE]: T.PRC.072



4.80 TL



GAZ TETİĞİ-2

THROTTLE TRIGGER-2

KOD [CODE]: T.PRC.086



4.30 TL

(P.R.C.) PALMERA / SECHO / ORAC / ENERGY / MITSUBISHI

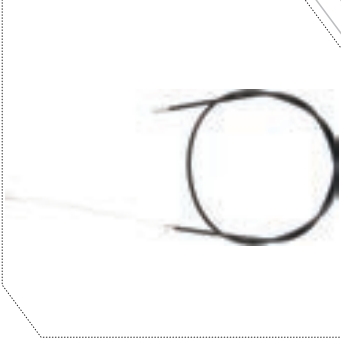

GAZ TELİ

THROTTLE CABLE

KOD [CODE]: T.PRC.017



7.50 TL



GAZ TETİĞİ

THROTTLE TRIGGER

KOD [CODE]: T.PRC.018



4.30 TL



GAZ TETİĞİ YERLİ ÜRETİM

TRIGGER INTERLOCK

KOD [CODE]: T.PRC.019



4.30 TL



HAVA FİLTRESİ ALT KAPAĞI

AIR FILTER COMP.

KOD [CODE]: T.PRC.020



3.50 TL



HAVA FİLTRESİ ALTI

AIR FILTER HOUSING

KOD [CODE]: T.PRC.021



5.00 TL



HAVA FİLTRESİ KAPAĞI

AIR FILTER COVER

KOD [CODE]: T.PRC.022



4.50 TL



HAVA FİLTRESİ TUTUCU

AIR FILTER PLATE

KOD [CODE]: T.PRC.023



2.50 TL



HAVA FİLTRESİ VE KAPAĞI

AIR FILTER AND COVER

KOD [CODE]: T.PRC.024



6.50 TL



HAVA FİLTRESİ SET

AIR FILTER KIT

KOD [CODE]: T.PRC.049



8.50 TL



HORTUM KİLİTLEME PİMİ (YERLİ ÜRETİM)





















FLEXIBLE SHAFT LOCK PIN

KOD [CODE]: T.PRC.088



9.00 TL

(P.R.C.) PALMERA / SECHO / ORAC / ENERGY / MITSUBISHI

	<p>İP MAKARASI STARTER PULLEY</p> <p>KOD [CODE]: T.PRC.057</p> <p> 4.50 TL</p>		<p>HORTUM BAĞLANTI BORUSU JOINT PIPE</p> <p>KOD [CODE]: T.PRC.025</p> <p> 12.50 TL</p>
	<p>HAVA FİLTRESİ SÜNGER AIR FILTER</p> <p>KOD [CODE]: T.PRC.090</p> <p> 2.50 TL</p>		<p>KARBÜRATÖR CARBURATOR</p> <p>KOD [CODE]: T.PRC.027</p> <p> 36.00 TL</p>
	<p>KARBÜRATÖR CARBURATOR 2</p> <p>KOD [CODE]: T.PRC.028</p> <p> 36.00 TL</p>		<p>KRANK CRANK</p> <p>KOD [CODE]: T.PRC.030</p> <p> 43.00 TL</p>
	<p>KOL BAĞLANTISI LOOP HANDLE CONNECTOR</p> <p>KOD [CODE]: T.PRC.058</p> <p> 16.75 TL</p>		<p>KARBÜRATÖR KÜTÜĞÜ CARBURATOR COMP.</p> <p>KOD [CODE]: T.PRC.029</p> <p> 5.50 TL</p>
	<p>BENZİN FİLTRESİ 4mm FUEL FILTER 4mm</p> <p>KOD [CODE]: T.PRC.065</p> <p> 3.50 TL</p>		<p>BENZİN FİLTRESİ 6mm FUEL FILTER 6mm</p> <p>KOD [CODE]: T.PRC.066</p> <p> 3.50 TL</p>

(P.R.C.) PALMERA / SECHO / ORAC / ENERGY / MITSUBISHI



**ALÜMİNYUM TIRNAKLI
MARŞ KOVANI GENİŞ
GÖBEK (EASY START İÇİN)**
STARTER PAUL (WIDE INNE
MODEL)

KOD [CODE]: T.PRC.100



8.00 TL



**MARŞ KOVANI DAR
GÖBEK**

STARTER PALW (DOUBLE ALU.
NAILED NARROW MODEL)

KOD [CODE]: T.PRC.098



8.00 TL



**KUTU FİLTRE (DOLU
SET)**
AIR FILLER
SET

KOD [CODE]: T.PRC.206



15.00 TL



**MARŞ TIRNAĞI
ALÜMİNYUM**

STARTER PAWL
NAIL

KOD [CODE]: T.PRC.101



2.20 TL



**MARŞ
KOVANI**

STARTER PAWL
SET

KOD [CODE]: T.PRC.031



6.20 TL



**MOTOR BAĞLANTI
SACI BİLYALI**

ENGINE MOUNT
PLATE

KOD [CODE]: T.PRC.032



20.00 TL



**MOTOR BAĞLANTI SACI
AMORTİSÖRLÜ**

ENGINE MOUNT PLATE
(WITH VIBRATION ISOLATOR)

KOD [CODE]: T.MK.015



30.00 TL



**MOTOR BAĞLANTI SACI
YAYLI**

ENGINE MOUNT PLATE (WITH
SPRING)

KOD [CODE]: T.MK.028



30.00 TL



**MOTOR BAĞLANTI
SACI**

ENGINE MOUNT
PLATE

KOD [CODE]: T.PRC.035



15.00 TL



**MOTOR BAĞLANTI
SACI YENİ**

ENGINE MOUNT PLATE
(NEW MODEL)

KOD [CODE]: T.PRC.036



20.00 TL

(P.R.C.) PALMERA / SECHO / ORAC / ENERGY / MITSUBISHI



**MOTOR BAĞLANTI SACI
ESKİ MODEL**

ENGINE MOUNT PLATE
(OLD MODEL)

KOD [CODE]: T.MK.014



18.00 TL



DEPO ALTI SAC AYAK

ENGINE MOUNT PLATE
COMPANENT

KOD [CODE]: T.PRC.204



5.00 TL



PİLOT KOL

LOOP HANDLE

KOD [CODE]: T.PRC.038



17.00 TL



**PİSTON SET
40 mm**

PISTON SET
40 MM

KOD [CODE]: T.PRC.081



17.00 TL



**PİSTON SET
44 mm**

PISTON SET
44 MM

KOD [CODE]: T.PRC.082



17.00 TL



PİSTON

PISTON

KOD [CODE]: T.PRC.039



14.00 TL



PİSTON 2

PISTON 2

KOD [CODE]: T.PRC.040



14.00 TL



SİLİNDİR

CYLINDER

KOD [CODE]: T.PRC.041



43.00 TL



**MOTOR BLOĞU
SAĞ**

CRANKCASE

KOD [CODE]: T.PRC.037



40.00 TL



SIRT ASKISI

HARNESS (FOR FLEXIBLE
SHAFT MODEL)

KOD [CODE]: T.ASK.005



58.00 TL

(P.R.C.) PALMERA / SECHO / ORAC / ENERGY / MITSUBISHI



SİRAL KİLİTLEME MANDALI
FLEXIBLE SHAFT LOCKER PIN

KOD [CODE]: T.PRC.045



8.50 TL



SİRAL MİL VE ALÜMİNYUM BORU

DRIVE SHAFT AND ALUMINIUM PIPE

KOD [CODE]: T.PRC.046



60.00 TL



SİRAL YUVASI
DRIVE SHAFT CONNECTOR

KOD [CODE]: T.PRC.047



8.50 TL



SİRAL YUVASI
FLEXIBLE SHAFT CONNECTOR

KOD [CODE]: T.PRC.089



9.00 TL



STARTER SET-1
STARTER

KOD [CODE]: T.PRC.026



19.00 TL



STARTER SET-2 (YAYLI)
STARTER SET-2

KOD [CODE]: T.PRC.073



25.00 TL



STARTER SET-3 (YAYLI)
STARTER SET-3

KOD [CODE]: T.PRC.074



25.00 TL



STARTER SET-4 (TELLİ)
STARTER SET-4

KOD [CODE]: T.PRC.104



25.00 TL



SİLİNDİR PİSTON SET 40 mm
CYLINDER PISTON SET 40 mm

KOD [CODE]: T.PRC.079



57.00 TL



SİLİNDİR PİSTON SET 44 mm
CYLINDER PISTON SET 44 mm

KOD [CODE]: T.PRC.080



57.00 TL

(P.R.C.) PALMERA / SECHO / ORAC / ENERGY / MITSUBISHI



**TETİK GRUBU
KOMPLE**
LEVER ASSEMBLY

KOD [CODE]: T.PRC.048



29.00 TL



TETİK GRUBU-1
LEVER ASSEMBLY-1

KOD [CODE]: T.PRC.083



30.00 TL



TETİK GRUBU-2
LEVER ASSEMBLY-2

KOD [CODE]: T.PRC.084



28.00 TL



**TETİK GRUBU
YAN MODEL**
LEVER ASSEMBLY
FOR STRAIGHT

KOD [CODE]: T.PRC.085



28.00 TL



**STARTER GÖBEĞİ
(ALÜMİNYUM)**
STARTER
COMPONENT

KOD [CODE]: T.PRC.091



8.00 TL



**BİLYALI TAS
(YERLİ ÜRETİM)**
ENGINE MOUNT PLATE COMP.

KOD [CODE]: T.PRC.087



10.00 TL



VOLANT
FLYWHEEL

KOD [CODE]: T.PRC.103



30.00 TL



ZEMBEREK-1
POWER SPRING-1

KOD [CODE]: T.PRC.075



5.00 TL



ZEMBEREK-2
POWER SPRING-2

KOD [CODE]: T.PRC.076



5.00 TL



ZEMBEREK-3
POWER SPRING-3

KOD [CODE]: T.PRC.077



5.00 TL

(P.R.C.) PALMERA / SECHO / ORAC / ENERGY / MITSUBISHI



**TETİK GRUBU
KOMPLE**
LEVER ASSEMBLY

KOD [CODE]: T.PRC.048



28.00 TL



TETİK GRUBU-1
LEVER ASSEMBLY-1

KOD [CODE]: T.PRC.083



28.00 TL



TETİK GRUBU-2
LEVER ASSEMBLY-2

KOD [CODE]: T.PRC.084



28.00 TL



**TETİK GRUBU
YAN MODEL**
LEVER ASSEMBLY
FOR STRAIGHT

KOD [CODE]: T.PRC.085



28.00 TL



**STARTER GÖBEĞİ
(ALÜMİNYUM)**
STARTER
COMPONENT

KOD [CODE]: T.PRC.091



8.00 TL



**BİLYALI TAS
(YERLİ ÜRETİM)**
ENGINE MOUNT PLATE COMP.

KOD [CODE]: T.PRC.087



10.00 TL



VOLANT
FLYWHEEL

KOD [CODE]: T.PRC.103



28.00 TL



ZEMBEREK-1
POWER SPRING-1

KOD [CODE]: T.PRC.075



4.20 TL



ZEMBEREK-2
POWER SPRING-2

KOD [CODE]: T.PRC.076



4.20 TL



ZEMBEREK-3
POWER SPRING-3

KOD [CODE]: T.PRC.077



4.20 TL

(P.R.C.) PALMERA / SECHO / ORAC / ENERGY / MITSUBISHI



**BALATA KOVANI
ALTI**
CLUTCH HOUSING COMP.

KOD [CODE]: **T.PRC.005**



19.00 TL



SİLİNDİR CONTASI
CYLINDER GASKET

KOD [CODE]: **T.PRC.212**



21.70 TL



MANTAR CONTA
GASKET (NON-PAPER)

KOD [CODE]: **T.PRC.211**



1.70 TL



**KARBÜRATÖR KÜTÜĞÜ
CONTASI 2**
CARBURATÖR GASKET 2
(INNER)

KOD [CODE]: **T.PRC.212**



1.00 TL



**KARBÜRATÖR KÜTÜĞÜ
CONTASI 1**
CARBURATOR GASKET 1
(INNER)

KOD [CODE]: **T.PRC.213**



1.00 TL



KARBÜRATÖR CONTASI
CARBURATOR GASKET

KOD [CODE]: **T.PRC.214**



1.00 TL

STIHL



**BALATA PABUCU
TAKIM**

CLUTCH

KOD [CODE]: T.STL.003



39.00 TL



**BATALATA
YAYI**

CLUTCH SPRING

KOD [CODE]: T.STL.004



1.30 TL



**BALATA BURCU
(ÖZEL ÇELİK)**

CLUTCH PART

KOD [CODE]: T.STL.031



7.00 TL



**BIÇAK SOMUNU
YAN MODEL**

BLADE COLLAR NUT (FOR
STRAIGHT SHAFT MODEL)

KOD [CODE]: T.STL.006



4.60 TL



**BIÇAK SOMUNU SIRT
MODEL**

BLADE COLLAR NUT (FOR
FLEXIBLE SHAFT MODEL)

KOD [CODE]: T.STL.007



4.60 TL



**BIÇAK TASI SIRT
MODEL**

RIDER GUIDE (FOR FLEXIBLE
SHAFT MODEL)

KOD [CODE]: T.STL.008



7.90 TL



**BENZİN
HORTUMU**

FUEL HOSE

KOD [CODE]: T.STL.005



4.20 TL



BUJİ BAŞLIĞI

SPARK PLUG BOOT

KOD [CODE]: T.STL.036



4.60 TL



KRANK KEÇESİ

OIL SEAL

KOD [CODE]: T.STL.101



Bilgi Alınız



**BIÇAK TASI YAN
MODEL**

RIDER GUIDE (FOR STRAIGHT
SHAFT MODEL)

KOD [CODE]: T.STL.009



7.90 TL

STIHL



**BIÇAK PULU
40/2**

THRUST PLATE
40/2

KOD [CODE]: **T.STL.035**



8.50 TL



**BIÇAK PULU
30/2**

THRUST PLATE
30/2

KOD [CODE]: **T.STL.034**



8.50 TL

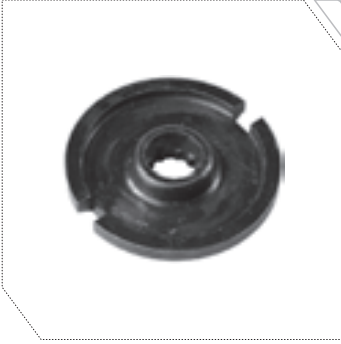

**FREZELİ PUL SIRT
MODEL**

THRUST PLATE (FOR FLEXIBLE
SHAFT MODEL)

KOD [CODE]: **T.STL.010**



19.00 TL



**FREZELİ KİLİTLEME
PULU**

THRUST PLATE STIHL (FOR
FLEXIBLE SHAFT MODEL)

KOD [CODE]: **T.STL.037**



23.00 TL



**FREZELİ PUL YAN
MODEL**

THRUST PLATE (FOR STRAIGHT
SHAFT MODEL)

KOD [CODE]: **T.STL.011**



22.00 TL



GAZ MİLİ

THROTTLE SHAFT

KOD [CODE]: **T.STL.012**



13.00 TL



**GAZ TELİ SIRT
(YENİ MODEL)**

THROTTLE CABLE (FOR
FLEXIBLE SHAFT NEW MODEL)

KOD [CODE]: **T.STL.032**



12.50 TL



**GAZ TELİ YAN
(YENİ MODEL)**

THROTTLE CABLE (FOR
STRAIGHT NEW MODEL)

KOD [CODE]: **T.STL.033**



12.50 TL



**HAVA
FİLTRESİ**

AIR
FILTER

KOD [CODE]: **T.STL.017**



3.30 TL



İP MAKARASI





















STARTER PULLEY

KOD [CODE]: **T.STL.018**



5.00 TL

STIHL

	<p>JİKLE KOLU CHOKE KNOB</p> <p>KOD [CODE]: T.STL.019</p> <p> 4.30 TL</p>		<p>MARŞ TIRNAĞI STARTER PAWL</p> <p>KOD [CODE]: T.STL.022</p> <p> 2.30 TL</p>
	<p>MARŞ TIRNAK YAYI STARTER PAWL SPRING</p> <p>KOD [CODE]: T.STL.023</p> <p> 1.20 TL</p>		<p>SİREL HORTUM BAĞLANTISI TAKIM JOINT PIPE SET</p> <p>KOD [CODE]: T.STL.020</p> <p> 75.00 TL</p>
	<p>SİREL HORTUM BAĞLANTISI BOŞ JOINT PIPE (EMPTY)</p> <p>KOD [CODE]: T.STL.021</p> <p> 40.00 TL</p>		<p>SİRAL KİLİTLEME MANDAL YAYI FLEXIBLE SHAFT LOCKER SPRING</p> <p>KOD [CODE]: T.STL.024</p> <p> 2.40 TL</p>
	<p>SİRAL KİLİTLEME MANDALI FLEXIBLE SHAFT LOCKER</p> <p>KOD [CODE]: T.STL.025</p> <p> 9.00 TL</p>		<p>SİRAL YUVASI DRIVE SHAFT CONNECTOR</p> <p>KOD [CODE]: T.STL.026</p> <p> 17.00 TL</p>
	<p>YAĞ TAPA CİVATASI OIL DRAIN PLUG</p> <p>KOD [CODE]: T.STL.027</p> <p> 1.70 TL</p>		<p>YAĞ TAPA CİVATASI GRASÖRLÜKLÜ GREASE NIPPLE</p> <p>KOD [CODE]: T.STL.028</p> <p> 3.20 TL</p>

STIHL



BİLYALI TAS

GUARD RING WITH
BEARING

KOD [CODE]: **T.STL.102**



13.00 TL



CONTA TAKIMI

GASKET SET

KOD [CODE]: **T.STL.038**



6.00 TL



SİLİNDİR CONTASI

SYLINDER GASKET

KOD [CODE]: **T.STL.103**



2.00 TL

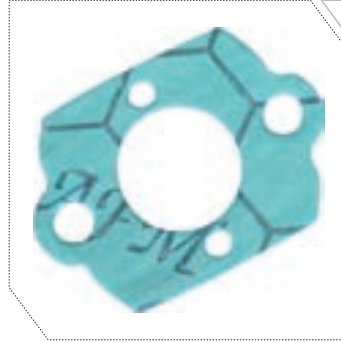

KARBÜRATÖR CONTASI

CARBURATOR GASKET

KOD [CODE]: **T.STL.104**



1.00 TL



EGSOZ CONTASI

MUFFLER GASKET

KOD [CODE]: **T.STL.103**



2.50 TL

SPİRAL HORTUM // FLEXIBLE SHAFT



İstenilen ebatta farklı giriş tiplerine uygun spiral hortum üretmekteyiz.

All flexible shafts will be produced by us according to your needs.

SPIRAL HORTUM // FLEXIBLE SHAFT



SPIRAL HORTUM GAZ TELİ BAĞLANTI KELEPÇESİ

THROTTLE CABLE CLAMP

KOD [CODE]: T.OE.115



2.80 TL



SPIRAL HORTUM ALPİNA CASTOR YENİ MODEL

FLEXIBLE SHAFT (ALPINA-CASTOR, NEW MODEL)

KOD [CODE]: T.SH.001



56.00 TL



SPIRAL HORTUM ALPİNA ESKİ MODEL

FLEXIBLE SHAFT (ALPINA, OLD MODEL)

KOD [CODE]: T.SH.002



48.00 TL



SPIRAL HORTUM STIHL

FLEXIBLE SHAFT (STIHL)

KOD [CODE]: T.SH.010



48.00 TL



SPIRAL HORTUM ERGO

FLEXIBLE SHAFT (ERGO)

KOD [CODE]: T.SH.004



56.00 TL



SPIRAL HORTUM BLUEBIRD

FLEXIBLE SHAFT (BLUEBIRD)

KOD [CODE]: T.SH.003



120.00 TL



SPIRAL HORTUM MITSUBISHI KAAZ

FLEXIBLE SHAFT (MITSUBISHI - KAAZ)

KOD [CODE]: T.SH.006



48.00 TL



SPIRAL HORTUM HUSQVARNA

FLEXIBLE SHAFT (HUSQVARNA)

KOD [CODE]: T.SH.005



60.00 TL



SPIRAL HORTUM OLEOMAC / EFCO

FLEXIBLE SHAFT (OLEO - MAC / EFCO)

KOD [CODE]: T.SH.007



48.00 TL



SPIRAL HORTUM PALMERA

FLEXIBLE SHAFT (PALMERA)

KOD [CODE]: T.SH.009



44.00 TL

SPİRAL HORTUM // FLEXIBLE SHAFT



**SPİRAL HORTUM OE ERGO
BİLYALI TAM SET**

THROTTLE CABLE
CLAMP

KOD [CODE]: T.SH.101



90.00 TL

BALATA // CLUTCH



**OLEO-MAC, ALPINA / CASTOR, STIHL,
KNC ve P.R.C. motorlar için balata
üretmekteyiz. Üretimin her aşaması
kendi tesislerimizde yapılmaktadır.
Tüm balatalarımızın kalitesi ve
sağlamlığı kanıtlanmıştır.**

We have all kinds of clutches for all model
and brands. Quality and strength of
clutches are proved.



Kaliteli Benzin Hortumu



KALIN TİP BENZİN HORTUMU

- Dış Çap : 5.50 mm
- İç Çap : 2.80 mm
- Uzunluk: 5 mt

KOD [CODE]: **BH.101**



12.00 TL



İNCE TİP BENZİN HORTUMU

- Dış Çap : 4.50 mm
- İç Çap : 2.00 mm
- Uzunluk: 5 mt

KOD [CODE]: **BH.102**



11.00 TL

SPIRAL MİL // FLEXIBLE DRIVE SHAFT



8 veya 9 mm kalınlığında özel ebatla spiral tel hazırlanmaktadır.

All flexible drive shafts will be produced by us according to your needs.

SPIRAL MİL KAAZ 89,5 cm
FLEXIBLE DRIVE SHAFT (KAAZ 89,5 cm)

KOD [CODE]: **T.SM.005**

14.00 TL

SPIRAL MİL STIHL 89 cm
FLEXIBLE DRIVE SHAFT (STIHL 89 cm)

KOD [CODE]: **T.SM.006**

14.00 TL

SPIRAL MİL SHINDAIWA 81 cm
FLEXIBLE DRIVE SHAFT (SHINDAIWA 81 cm)

KOD [CODE]: **T.SM.007**

14.00 TL

SPIRAL MİL MITSUBISHI 93,5 cm
FLEXIBLE DRIVE SHAFT (MITSUBISHI 93,5 cm)

KOD [CODE]: **T.SM.008**

14.00 TL

SPIRAL MİL BLUEBIRD 107,5 cm (9 mm)
FLEXIBLE DRIVE SHAFT (BLUEBIRD 107,5 cm) (9 mm)

KOD [CODE]: **T.SM.009**

50.00 TL

SPIRAL MİL ACTIVE 89,7 cm
FLEXIBLE DRIVE SHAFT (ACTIVE 89,7 cm)

KOD [CODE]: **T.SM.001**

14.00 TL

SPIRAL MİL HUSQVARNA 99,2 cm
FLEXIBLE DRIVE SHAFT (HUSQVARNA 99,2 cm)

KOD [CODE]: **T.SM.010**

14.00 TL

SPIRAL MİL ALPINA YENİ MODEL 101 cm
FLEXIBLE DRIVE SHAFT (ALPINA NEW MODEL 101 cm)

KOD [CODE]: **T.SM.002**

14.00 TL

SPIRAL MİL DOLMAR 91 cm
FLEXIBLE DRIVE SHAFT (DOLMAR 91 cm)

KOD [CODE]: **T.SM.011**

14.00 TL

SPIRAL MİL ALPINA ESKİ MODEL 84,5 cm
KOD [CODE]: **T.SM.003**

KOD [CODE]: **T.SM.014**

14.00 TL

SPIRAL MİL PALMERA P.R.C TÜM MODELLERE 79,2 cm
FLEXIBLE DRIVE SHAFT (PALMERA P.R.C ALL MODELS 79,2 cm)

KOD [CODE]: **T.SM.012**

14.00 TL

SPIRAL MİL OLEO-MAC / EFCO 94,5 cm
FLEXIBLE DRIVE SHAFT (OLEO-MAC / EFCO 94,5 cm)

KOD [CODE]: **T.SM.004**

14.00 TL

SPIRAL MİL KAWASAKI ZEYTİN TOPLAMA MAK. 101 cm
FLEXIBLE DRIVE SHAFT (KAWASAKI 101 cm)

KOD [CODE]: **T.SM.013**

14.00 TL

GAZ TELİ // THROTTLE CABLE



İstenilen farklı giriş tiplerine uygun, istenilen tel kalınlığında veya uzunluğunda yüksek kaliteli gaz teli üretimini firmamız bünyesinde gerçekleştirmekteyiz.

All throttle cables will be produced by us according to your needs.

ÇİM BİÇME MAKİNESİ YEDEK PARÇALARI

LAWN MOWER SPARE PARTS



ÇİM BİÇME BİÇAKLARI // LAWN MOWER BLADES



ELEKTRİKLİ ÇİM BİÇME MAKİNASI BİÇAKLARI İÇİN BİLGİ ALINIZ.

Bilgi Alınız.

BİÇAKLAR / BLADES

Üretimi tamamen kendi bünyemizde ve her aşaması kontrol edilerek sunulmaktadır. Bütün bıçaklarımız standart ve en iyi kalitededir. Türkiye'de üretilen en kaliteli bıçaklar "KM BLADES" profesyoneller için hazır.

Blades are totally produced by us and they are controlled every step of production. All blades have same and best quality. The best quality blades "KM BLADES" which are produced in Turkey are ready for professionals.



- 46 cm Uzunluk
- 10 mm Merkez Delik Çapı
- Formlu / Standart

LAND MOWER BLADE

KOD [CODE]: BK.001

 **23.00 TL**



- 46 cm Uzunluk
- 10 mm Merkez Delik Çapı
- Formlu / Hafif Tip

LAND MOWER BLADE

KOD [CODE]: BK.002

 **22.00 TL**



- 46 cm Uzunluk
- 18 mm Merkez Delik Çapı
- Formlu / Hafif Tip

LAND MOWER BLADE

KOD [CODE]: BK.003

 **22.00 TL**



- 46 cm Uzunluk
- Tüm Modellere Uygun
- Formlu / Kanatlı

LAND MOWER BLADE

KOD [CODE]: BK.004

 **25.00 TL**



- 46 cm Uzunluk
- 18 mm Merkez Delik Çapı
- Formlu / Ters Tip Kanatlı

LAND MOWER BLADE

KOD [CODE]: BK.005

 **25.00 TL**



- 46 cm Uzunluk
- 10 mm Merkez Delik Çapı
- Formlu / Standart Tip

LAND MOWER BLADE

KOD [CODE]: BK.006

 **23.00 TL**

ÇİM BİÇME BİÇAKLARI // LAWN MOWER BLADES



- 46 cm Uzunluk
- 18 mm Merkez Delik Çapı
- Formlu / Kanatlı Tip

LAND MOWER
BLADE

KOD [CODE]: BK.007



25.00 TL



- 46 cm Uzunluk
- 10 mm Merkez Delik Çapı
- Formlu / Kanatlı tip

LAND MOWER
BLADE

KOD [CODE]: BK.008



25.00 TL



- 47 cm Uzunluk
- 18 mm Merkez Delik Çapı
- Formlu / Hafif Tip

LAND MOWER
BLADE

KOD [CODE]: BK.009



23.00 TL



- 47 cm Uzunluk
- 10 mm Merkez Delik Çapı
- Formlu / Standart Tip

LAND MOWER
BLADE

KOD [CODE]: BK.010



24.00 TL



- 47 cm Uzunluk
- 10 mm Merkez Delik Çapı
- Formlu / Hafif Tip

LAND MOWER
BLADE

KOD [CODE]: BK.011



23.00 TL



- 48 cm Uzunluk
- 10 mm Merkez Delik Çapı
- Formlu / Standart

LAND MOWER
BLADE

KOD [CODE]: BK.012



24.00 TL



- 48 cm Uzunluk
- 18 mm Merkez Delik Çapı
- Formlu / Standart Tip

LAND MOWER
BLADE

KOD [CODE]: BK.013



25.00 TL



- 48 cm Uzunluk
- 18 mm Merkez Delik Çapı
- Formlu / Hafif Tip

LAND MOWER
BLADE

KOD [CODE]: BK.014



24.00 TL



- 48 cm Uzunluk
- 10 mm Merkez Delik Çapı
- Formlu / Hafif Tip

LAND MOWER
BLADE

KOD [CODE]: BK.015



24.00 TL



- 49 cm Uzunluk
- 18 mm Merkez Delik Çapı
- Formlu / Standart Tip

LAND MOWER
BLADE

KOD [CODE]: BK.016



25.00 TL

ÇİM BİÇME BİÇAKLARI // LAWN MOWER BLADES



- 49 cm Uzunluk
- 18 mm Merkez Delik Çapı
- Formlu / Kanatlı Tip

LAND MOWER
BLADE

KOD [CODE]: BK.017



26.00 TL



- 49 cm Uzunluk
- 18 mm Merkez Delik Çapı
- Formlu / Hafif Tip

LAND MOWER
BLADE

KOD [CODE]: BK.018



24.00 TL



- 49 cm Uzunluk
- 10 mm Merkez Delik Çapı
- Formlu / Kanatlı Tip

LAND MOWER
BLADE

KOD [CODE]: BK.019



26.00 TL



- 49 cm Uzunluk
- 10 mm Merkez Delik Çapı
- Formlu / Hafif Tip

LAND MOWER
BLADE

KOD [CODE]: BK.020



24.00 TL



- 50 cm Uzunluk
- 18 mm Merkez Delik Çapı
- Formlu / Standart

LAND MOWER
BLADE

KOD [CODE]: BK.021



25.00 TL



- 50 cm Uzunluk
- 18 mm Merkez Delik Çapı
- Formlu / Hafif Tip

LAND MOWER
BLADE

KOD [CODE]: BK.022



24.00 TL



- 50 cm Uzunluk
- 10 mm Merkez Delik Çapı
- Formlu / Hafif Tip

LAND MOWER
BLADE

KOD [CODE]: BK.023



24.00 TL



- 50 cm Uzunluk
- 10 mm Merkez Delik Çapı
- Formlu / Standart

LAND MOWER
BLADE

KOD [CODE]: BK.024



25.00 TL



- 51 cm Uzunluk
- 18 mm Merkez Delik Çapı
- Formlu / Hafif Tip

LAND MOWER
BLADE

KOD [CODE]: BK.025



24.00 TL



- 51 cm Uzunluk
- 10 mm Merkez Delik Çapı
- Formlu / Hafif Tip

LAND MOWER
BLADE

KOD [CODE]: BK.026



24.00 TL

ÇİM BİÇME BİÇAKLARI // LAWN MOWER BLADES



- 51 cm Uzunluk
- Tüm Modellere Uygun
- Formlu / Kanatlı

LAND MOWER
BLADE

KOD [CODE]: BK.027



26.00 TL



- 51 cm Uzunluk
- 10 mm Merkez Delik Çapı
- Formlu / Standart

LAND MOWER
BLADE

KOD [CODE]: BK.028



25.00 TL



- 51 cm Uzunluk
- 18 mm Merkez Delik Çapı
- Formlu / Standart

LAND MOWER
BLADE

KOD [CODE]: BK.029



25.00 TL



- 52 cm Uzunluk
- 18 mm Merkez Delik Çapı
- Formlu / Standart

LAND MOWER
BLADE

KOD [CODE]: BK.030



25.00 TL



- 52 cm Uzunluk
- 10 mm Merkez Delik Çapı
- Formlu / Hafif Tip

LAND MOWER
BLADE

KOD [CODE]: BK.031



25.00 TL



- 52 cm Uzunluk
- 18 mm Merkez Delik Çapı
- Formlu / Hafif Tip

LAND MOWER
BLADE

KOD [CODE]: BK.032



25.00 TL



- 52 cm Uzunluk
- 18 mm Merkez Delik Çapı
- Formlu / Standart

LAND MOWER
BLADE

KOD [CODE]: BK.033



27.00 TL



- 53 cm Uzunluk
- 18 mm Merkez Delik Çapı
- Formlu / Kanatlı

LAND MOWER
BLADE

KOD [CODE]: BK.034



28.00 TL



- 53 cm Uzunluk
- 18 mm Merkez Delik Çapı
- Formlu / Ters Tip Kanatlı

LAND MOWER
BLADE

KOD [CODE]: BK.035



28.00 TL



- 53 cm Uzunluk
- Tüm Modellere Uygun
- Formlu / Standart





















LAND MOWER
BLADE

KOD [CODE]: BK.036



27.00 TL

BENZİNLİ // GASOLINE POWERED

	<p>CONTA 1 GASKET 1 KOD [CODE]: CB.BEN.001</p> <p> 1.70 TL</p>		<p>CONTA 2 GASKET 2 KOD [CODE]: CB.BEN.002</p> <p> 1.70 TL</p>
	<p>CONTA 3 GASKET 3 KOD [CODE]: CB.BEN.003</p> <p> 1.70 TL</p>		<p>CONTA 4 GASKET 4 KOD [CODE]: CB.BEN.004</p> <p> 1.70 TL</p>
	<p>CONTA 5 GASKET 5 KOD [CODE]: CB.BEN.005</p> <p> 1.70 TL</p>		<p>DİYAFRAM DIAPHRAGM KOD [CODE]: CB.BEN.006</p> <p> 3.50 TL</p>
	<p>GAZ KOLU THROTTLE LEVER KOD [CODE]: CB.BEN.007</p> <p> 19.00 TL</p>		<p>GAZ KOLU TELLİ THROTTLE LEVER (WITH CABLE) KOD [CODE]: CB.BEN.008</p> <p> 23.00 TL</p>
	<p>GAZ MİLİ BRIGGS THROTTLE SHAFT (BRIGGS) KOD [CODE]: CB.BEN.009</p> <p> 9.00 TL</p>		<p>GAZ MİLİ TECUMSEH THROTTLE SHAFT (TECUMSEH) KOD [CODE]: CB.BEN.010</p> <p> 9.00 TL</p>

BENZİNLİ // GASOLINE POWERED



**GAZ TELİ
TUTUCU**

THROTTLE CABLE
CLAMP

KOD [CODE]: T.AC.029



2.25 TL



**GAZ TELİ
KISA**

THROTTLE CABLE
(SHORT)

KOD [CODE]: CB.BEN.012



6.50 TL



**GAZ TELİ
UZUN**

THROTTLE CABLE
(LONG)

KOD [CODE]: CB.BEN.013



6.50 TL

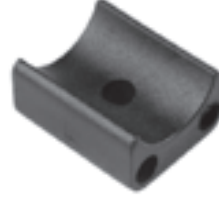

**GAZ TELİ
YUVASI**

THROTTLE CABLE
HOLDER

KOD [CODE]: CB.BEN.014



4.25 TL



**HAVA
FİLTRESİ**

AIR FILTER

KOD [CODE]: CB.BEN.048



4.75 TL



**HAVA FİLTRESİ
5 - 5,5 HP**

AIR FILTER
(FOR 5 - 5,5 HP)

KOD [CODE]: CB.BEN.015



4.75 TL



**HAVA FİLTRESİ
9 HP**

AIR FILTER
(FOR 9 HP)

KOD [CODE]: CB.BEN.016



7.25 TL



**İP ÇEKME
SAPI**

STARTER
HANDLE

KOD [CODE]: CB.BEN.017



3.25 TL



**İP MAKARASI
3,75 HP**

STARTER PULLEY
(3,75 HP)

KOD [CODE]: CB.BEN.018



11.50 TL



**İP MAKARASI
4 HP**

STARTER PULLEY
(4 HP)

KOD [CODE]: CB.BEN.019



11.50 TL

BENZİNLİ // GASOLINE POWERED



**İP MAKARASI
5 - 5,5 HP**

STARTER PULLEY
(5 - 5,5 HP)

KOD [CODE]: **CB.BEN.020**



11.50 TL



**İP MAKARASI
5 HP**

STARTER PULLEY
(5 HP)

KOD [CODE]: **CB.BEN.021**



11.50 TL



**JİKLE
LASTİĞİ**

PRIMER
BULB

KOD [CODE]: **CB.BEN.022**



3.25 TL



**JİKLE LASTİĞİ
DELİKLİ**

PRIMER BULB
(WITH HOLE)

KOD [CODE]: **CB.BEN.023**



3.25 TL



**KAFA
CONTASI 1**

CYLINDER
GASKET 1

KOD [CODE]: **CB.BEN.024**



4.25 TL



**KAFA
CONTASI 2**

CYLINDER
GASKET 2

KOD [CODE]: **CB.BEN.025**



4.25 TL



**KAFA
CONTASI 3**

CYLINDER
GASKET 3

KOD [CODE]: **CB.BEN.026**



4.25 TL



**KAFA
CONTASI 4**

CYLINDER
GASKET 4

KOD [CODE]: **CB.BEN.027**



4.25 TL



**KAFA
CONTASI 5**

CYLINDER
GASKET 5

KOD [CODE]: **CB.BEN.028**



4.25 TL



**KOL BAĞLANTI
VİDASI TAKIMI**

HANDLEBAR BOLT
AND NUT SET

KOD [CODE]: **CB.BEN.036**



5.25 TL

BENZİNLİ // GASOLINE POWERED



**KAPLİN (ADAPTÖR)
CASTEL**

BLADE ADAPTOR
(CASTEL)

KOD [CODE]: **CB.BEN.030**



14.00 TL



**KAPLİN (ADAPTÖR)
OLEO-MAC / EFCO / 22 mm**

BLADE ADAPTOR
(OLEO-MAC / EFCO) / 22 mm

KOD [CODE]: **CB.BEN.031**



14.00 TL



**KAPLİN (ADAPTÖR)
CASTEL / AĞIR TİP**

BLADE ADAPTOR
(CASTEL)

KOD [CODE]: **CB.BEN.048**



14.00 TL



**KAPLİN (ADAPTÖR)
OLEO-MAC / EFCO / 25 mm**

BLADE ADAPTOR
(OLEO-MAC / EFCO) / 25 mm

KOD [CODE]: **CB.BEN.049**



14.00 TL



**KAPLİN (ADAPTÖR)
OLEO-MAC / EFCO
AĞIR TİP**

BLADE ADAPTOR
(OLEO-MAC / EFCO)

KOD [CODE]: **CB.BEN.050**



14.00 TL



**MANİFOLT BORUSU
5 - 5,5 HP**

MANIFOLD
(5 - 5,5 HP)

KOD [CODE]: **CB.BEN.038**



11.50 TL



**MARŞ TIRNAĞI
METAL**

STARTER PAWL
(METAL TYPE)

KOD [CODE]: **CB.BEN.040**



6.20 TL



**MANİFOLT BORUSU
3,75 HP**

MANIFOLD
(3,75 HP)

KOD [CODE]: **CB.BEN.037**



11.50 TL



**MARŞ TIRNAĞI
UZUN**

STARTER PAWL
(LONG TYPE)

KOD [CODE]: **CB.BEN.041**



2.50 TL



**MARŞ TIRNAĞI
KISA**

STARTER PAWL
(SHORT TYPE)

KOD [CODE]: **CB.BEN.039**



2.50 TL

BENZİNLİ // GASOLINE POWERED



**KAPLİN
KAMASI**

BLADE ADAPTOR
KEY

KOD [CODE]: **CB.BEN.032**



3.60 TL



**KAPLİN
KAMASI 2**

BLADE ADAPTOR
KEY 2

KOD [CODE]: **CB.BEN.033**



3.60 TL

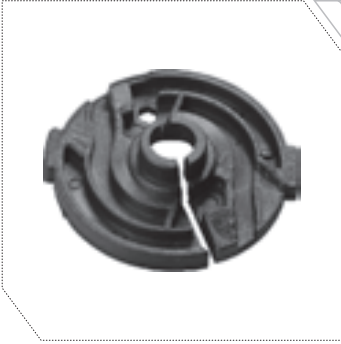

**MARŞ TIRNAK
KLAVUZU**

STARTER PAWL
GUIDE

KOD [CODE]: **CB.BEN.042**



5.70 TL



**MARŞ TIRNAK
YAYI**

STARTER PAWL
SPRING

KOD [CODE]: **CB.BEN.043**



2.60 TL



TEKERLEK

WHEEL

KOD [CODE]: **CB.BEN.044**



8.25 TL



**TEKERLEK
BURCU**

WHEEL
BUSHING

KOD [CODE]: **CB.BEN.045**



2.75 TL



**VOLANT KAMASI
TECUMSEH**

FLYWHEEL KEY
(TECUMSEH)

KOD [CODE]: **CB.BEN.046**



3.25 TL



**YAĞ TAPA
ANAHTARI**

OIL FILLER CAP
KEY

KOD [CODE]: **CB.BEN.047**



4.25 TL



**KARTER
CONTASI**

CRANKCASE
GASKET

KOD [CODE]: **CB.BEN.034**



3.25 TL

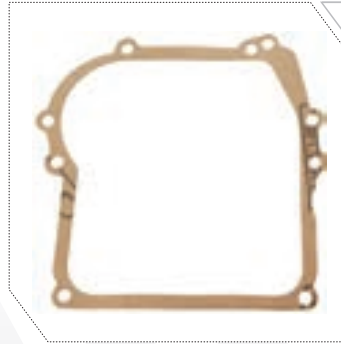

**KARTER
CONTASI 2**

CRANKCASE
GASKET 2

KOD [CODE]: **CB.BEN.035**



3.25 TL

ELEKTRİKLİ // ELECTRICAL POWERED



**BIÇAK CİVATASI
DAR**

BLADE BOLT
(NARROW)

KOD [CODE]: **CB.ELK.001**



7.25 TL



**BIÇAK CİVATASI
GENİŞ**

BLADE BOLT
(WIDE)

KOD [CODE]: **CB.ELK.002**



7.25 TL



**PERVANE DAR
DELİK**

FAN (WITH NARROW
HOLE)

KOD [CODE]: **CB.ELK.003**



12.25 TL



**PERVANE GENİŞ
DELİK**

FAN (WITH WIDE
HOLE)

KOD [CODE]: **CB.ELK.004**



12.25 TL



**PERVANE
KIWI**

FAN (KIWI)

KOD [CODE]: **CB.ELK.005**



11.00 TL



**TEKERLEK
KÜÇÜK**

WHEEL
(SMALL)

KOD [CODE]: **CB.ELK.006**



8.50 TL



**TEKERLEK
BÜYÜK**

WHEEL (BIG)

KOD [CODE]: **CB.ELK.007**



8.50 TL



İLACLAMA MAKİNESİ YEDEK PARÇALARI
MISTBLOWER & KNAPSACK POWER SPRAYERS
SPARE PARTS



AMORTİSÖR

VIBRATION ISOLATOR

KOD [CODE]: IM.PL.001



5.20 TL



ARA HORTUM 1

HOSE 1

KOD [CODE]: IM.PL.002



4.20 TL



ARA HORTUM 2

HOSE 2

KOD [CODE]: IM.PL.003



4.20 TL



ARA HORTUM 3

HOSE 3

KOD [CODE]: IM.PL.004



4.20 TL



ASKI KAYIŞI

HARNESS

KOD [CODE]: IM.PL.005



12.25 TL



BALATA CİVATASI

CLUTCH BOLT

KOD [CODE]: IM.PL.006



2.40 TL



BALATA

CLUTCH

KOD [CODE]: IM.PL.007



10.00 TL



BASINÇ BALANS MİLİ

PRESSURE SHAFT

KOD [CODE]: IM.PL.008



22.00 TL



BASINÇ POMPASI TAMİR TAKIMI

ORİNG CASSET SET

KOD [CODE]: IM.PL.009



Bilgi Alınız.



BENZİN DEPO KAPAĞI

FUEL COP

KOD [CODE]: IM.PL.010



2.95 TL



**BENZİN DEPO
HORTUMU SETİ**
FUEL HOSE KIT

KOD [CODE]: **IM.PL.011**



6.25 TL



**ELEKTRONİK
BOBİN**
IGNITION COIL

KOD [CODE]: **IM.PL.012**



27.00 TL



GAZ KOLU
THROTTLE LEVER

KOD [CODE]: **IM.PL.013**



5.15 TL



GAZ TELİ
THROTTLE CABLE

KOD [CODE]: **IM.PL.014**



4.25 TL



**HAVA FİLTRESİ
SETİ**
AIR FILTER
SET

KOD [CODE]: **IM.PL.015**



3.25 TL



**İLAÇ DEPOSU
KAPAĞI**
CHEMICAL TANK
COP

KOD [CODE]: **IM.PL.016**



12.00 TL



**İLAÇLAMA
HORTUMU**
SHEMICAL
HOSE

KOD [CODE]: **IM.PL.017**



11.50 TL



**İLAÇLAMA
MUŞLUĞU**
TAP

KOD [CODE]: **IM.PL.018**



20.00 TL



KARBÜRATÖR
CARBURATOR

KOD [CODE]: **IM.PL.019**



33.00 TL



**KARBÜRATÖR
TAKOZU**
CARBURATOR COMP

KOD [CODE]: **IM.PL.020**



5.30 TL

SIRT TIPI PULVERİZATÖR (P.R.C.) // KNAPSACK POWER SPRAYERS



MARŞ KOVANI
STARTER PAUL SET

KOD [CODE]: IM.PL.021



5.00 TL



PİSTON 33 MM

PİSTON 33 MM

KOD [CODE]: IM.PL.022



12.00 TL



PÜSKÜRTME DEMİRİ VE KABZE SETİ
NOZZLE SET

KOD [CODE]: IM.PL.023



17.00 TL



SİLİNDİR PİSTON SET 33 MM
CYLINDER PISTON SET 33 MM

KOD [CODE]: IM.PL.024



58.00 TL



SIRT ASKISI
HARNESS

KOD [CODE]: IM.PL.025



13.00 TL



STARTER SET
STARTER SET

KOD [CODE]: IM.PL.026



18.00 TL



STOP ANAHTARI
ON OF BUTTON

KOD [CODE]: IM.PL.027



5.20 TL



UCU KIVRIK GAZ TELİ UZUN
THROTTLE CABLE (L CONNECT)

KOD [CODE]: T.PRC.301



16.00 TL

STIHL



STIHL İLAÇLAMA HAVA FİLTRESİ
AIR FILTER MIST DUSTER STIHL

KOD [CODE]: IM.STL.001



4.95 TL

ATOMİZÖR (P.R.C.) // MISTBLOWER



AMORTİSÖR

VIBRATION
ISOLATOR

KOD [CODE]: **IM.PRC.001**



5.20 TL



AMORTİSÖR 2

VIBRATION
ISOLATOR 2

KOD [CODE]: **IM.PRC.002**



5.20 TL



**AMORTİSÖR
SAC**

VIBRATION ISOLATOR
(SHEET METAL)

KOD [CODE]: **IM.PRC.003**



8.50 TL



**AMORTİSÖR YAY
OLEO-MAC**

VIBRATION ISOLATOR
(SPRING, OLEO-MAC / EFCO)

KOD [CODE]: **IM.PRC.004**



8.50 TL



**BAĞLANTI
PARÇASI**

LINK FRAME

KOD [CODE]: **IM.PRC.005**



12.50 TL



**BENZİN DEPO KAPAĞI
VE CONTASI**

FUEL FILLER CAP
AND GASKET

KOD [CODE]: **IM.PRC.006**



4.50 TL



**BENZİN
DEPOSU**

FUEL TANK

KOD [CODE]: **IM.PRC.007**



24.00 TL



**BENZİN
HORTUMU**

FUEL HOSE

KOD [CODE]: **IM.PRC.008**



15.00 TL



**BENZİN
ÖLÇEĞİ**

FUEL MEASURING
CAP

KOD [CODE]: **T.AKS.004**



5.50 TL



**BENZİN
MUSLUĞU**





















FUEL TAP

KOD [CODE]: **IM.PRC.053**



9.00 TL

ATOMİZÖR (P.R.C.) // MISTBLOWER

	<p>BENZİN MUSLUK CİVATASI SÜZGEÇLİ FUEL TAP BOLT (WITH FILTER) KOD [CODE]: IM.PRC.009</p>  <p>6.50 TL</p>		<p>BENZİN SÜZGEÇİ FUEL FILTER KOD [CODE]: IM.PRC.010</p>  <p>5.50 TL</p>
	<p>BOBİN IGNITION COIL KOD [CODE]: IM.PRC.011</p>  <p>37.00 TL</p>		<p>BOBİN 2 IGNITION COIL 2 KOD [CODE]: IM.PRC.065</p>  <p>36.00 TL</p>
	<p>CONTA SİSLEME GASKET KOD [CODE]: IM.PRC.013</p>  <p>12.00 TL</p>		<p>CONTA SİSLEME 2 GASKET 2 KOD [CODE]: IM.PRC.014</p>  <p>12.00 TL</p>
	<p>CONTA SİSLEME 3 GASKET 3 KOD [CODE]: IM.PRC.015</p>  <p>12.00 TL</p>		<p>CONTA SİSLEME LASTİĞİ RUBBER COMPONENT KOD [CODE]: IM.PRC.016</p>  <p>11.00 TL</p>
	<p>DEPO ÇIKIŞI TANK COMP. KOD [CODE]: IM.PRC.057</p>  <p>6.50 TL</p>		<p>DEPO KAPAĞI CHEMICAL TANK CAP KOD [CODE]: IM.PRC.017</p>  <p>16.50 TL</p>

ATOMİZÖR (P.R.C.) // MISTBLOWER



DESTEK

HARNESS

KOD [CODE]: **IM.PRC.019**



25.00 TL



EGSOZ MUHAFAZASI

MUFFLER COVER

KOD [CODE]: **IM.PRC.020**



11.00 TL

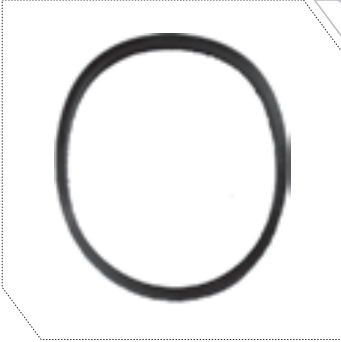

DEPO KAPAĞI CONTASI (SİLİKON)

CHEMICAL TANK CAP GASKET

KOD [CODE]: **IM.PRC.018**



7.00 TL



EGSOZ SACI

MUFFLER SCREEN FRAME

KOD [CODE]: **IM.PRC.021**



7.00 TL



EGSOZ SACI 2

MUFFLER SCREEN FRAME 2

KOD [CODE]: **IM.PRC.066**



7.00 TL



FAN

İMPERLER

KOD [CODE]: **IM.PRC.023**



42.00 TL

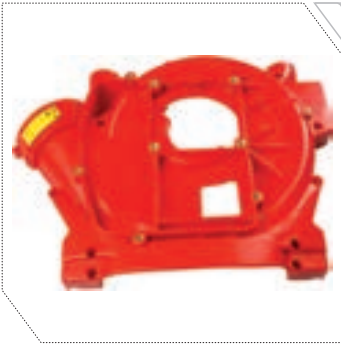

FAN YUVASI SET

İMPERLER COVER SET

KOD [CODE]: **IM.PRC.024**



80.00 TL

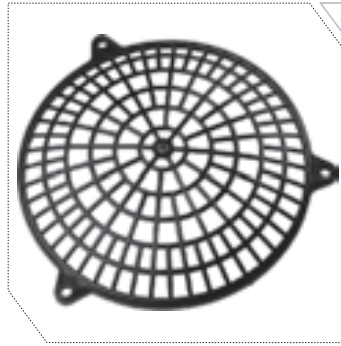

FİLTRE

NET COVER

KOD [CODE]: **IM.PRC.025**



6.00 TL

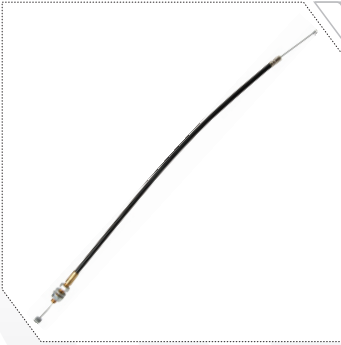

GAZ TELİ

THROTTLE CABLE

KOD [CODE]: **IM.PRC.026**



4.50 TL



HAVA FİLTRESİ

AIR FILTER

KOD [CODE]: **IM.PRC.027**



9.00 TL

ATOMİZÖR (P.R.C.) // MISTBLOWER



**HIZ
TERTİBATI**

THROTTLE
LEVER

KOD [CODE]: **IM.PRC.028**



22.00 TL



**HORTUM
KÖRÜKLÜ**

FLEXIBLE
HOSE

KOD [CODE]: **IM.PRC.029**



19.00 TL



**HORTUM
TUTACAĞI**

HOSE
HOLDER

KOD [CODE]: **IM.PRC.030**



13.00 TL



HORTUM

HOSE

KOD [CODE]: **IM.PRC.058**



6.00 TL



**HAREKETLİ NOZUL
GÖBEĞİ**

ROTATING NOZZLE
COMP.

KOD [CODE]: **IM.PRC.056**



4.50 TL



**İLAÇ
HORTUMU**

PESTICIDES
HOSE

KOD [CODE]: **IM.PRC.055**



4.50 TL



**HORTUM
ÜFLEME**

BEND HOSE

KOD [CODE]: **IM.PRC.031**



13.00 TL



**İLAÇ
FİLTRESİ**

FILTER

KOD [CODE]: **IM.PRC.032**



12.00 TL

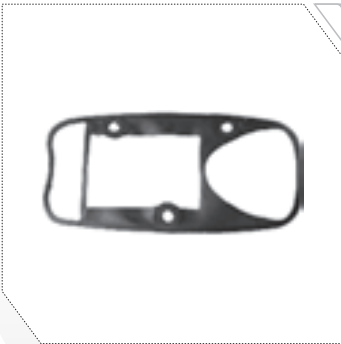

**İLAÇ YUVASI
CONTASI**

DUSTING PLATE
GASKET

KOD [CODE]: **IM.PRC.033**



6.00 TL



**İLAÇ YUVASI
VE CONTASI**

DUSTING PLATE
AND GASKET

KOD [CODE]: **IM.PRC.034**



20.00 TL

ATOMİZÖR (P.R.C.) // MISTBLOWER



**KARBURATÖR
(AYAR CİVATASIZ)**
CARBURATOR
(WITHOUT ADJUSTING SCREW)

KOD [CODE]: IM.PRC.060



44.00 TL



**KARBÜRATÖR
(AYAR CİVATALI)**
CARBURATOR (WITH
ADJUSTING SCREW)

KOD [CODE]: IM.PRC.035



44.00 TL



KRANK
CRANK

KOD [CODE]: IM.PRC.036



52.00 TL



**MARŞ
KOVANI**
STARTER PAWL
(METAL)

KOD [CODE]: IM.PRC.037



6.00 TL



NOZUL
NOZZLE ASSY.

KOD [CODE]: IM.PRC.038



20.00 TL



**PİSTON
SET**
PISTON
SET

KOD [CODE]: IM.PRC.039



18.00 TL



**POMPA
LASTİĞİ**
RUBBER
COMP.

KOD [CODE]: IM.PRC.040



11.00 TL



**SİLİNDİR PİSTON
SET**
CYLINDER PISTON
SET

KOD [CODE]: IM.PRC.041



60.00 TL



**SİLİNDİR
BAĞLANTISI**
CYLINDER CONNECTOR
COMP.

KOD [CODE]: IM.PRC.042



11.00 TL



**SİS YUVA
TERTİBATI**
DUSTING PLATE
COMP.

KOD [CODE]: IM.PRC.043



11.00 TL

ATOMİZÖR (P.R.C.) // MISTBLOWER



STARTER

STARTER

KOD [CODE]: **IM.PRC.044**



27.00 TL



STARTER SİYAH GÖBEK

MIDDLE BLACK COMP. OF STARTER

KOD [CODE]: **IM.PRC.045**



6.00 TL



SU MUSLUĞU

WATER TAP

KOD [CODE]: **IM.PRC.046**



7.00 TL



SU MUSLUĞU VE HORTUMU

WATER TAP AND HOSE

KOD [CODE]: **IM.PRC.047**



9.00 TL



ŞEFFAF HORTUM 4mm (YERLİ ÜRETİM)

HOSE 4 mm

KOD [CODE]: **IM.PRC.059**



3.00 TL



VALF

SHUTTER CASE

KOD [CODE]: **IM.PRC.048**



36.00 TL



VALF MANDALI (SİYAH KISIM)

RIGHT BLACK PART OF SHUTTER CASE

KOD [CODE]: **IM.PRC.049**



6.00 TL



VALF ORTA KAUÇUĞU (SİYAH KISIM)

MIDDLE BLACK PART OF SHUTTER CASE

KOD [CODE]: **IM.PRC.050**



8.00 TL



VOLANT

FLYWHEEL

KOD [CODE]: **IM.PRC.051**



30.00 TL



VALF GÖBEK PLASTİĞİ

SHUTTER CASE COMP.

KOD [CODE]: **IM.PRC.054**



8.00 TL

KESİM MOTORU YEDEK PARÇALARI
CHAINSAW SPARE PARTS

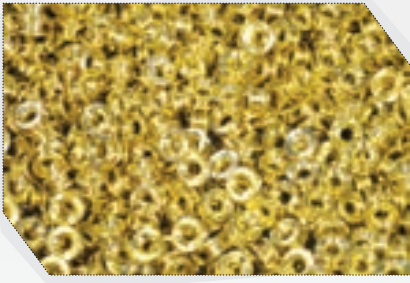

AKSESUAR // ACCESSORIES



BUJİ ANAHTARI
13-19 mm

SCRENCH
(13-19 mm)

KOD [CODE]: T.AKS.005



3.60 TL



BUJİ ANAHTARI
17-19 mm

SCRENCH
(17-19 mm)

KOD [CODE]: T.AKS.006



3.60 TL



EĞE SAPI

CHAINSAW FILE
HOLDER

KOD [CODE]: KM.AKS.003



1.75 TL



EĞELEME
APARATI

CHAINSAW
FILE

KOD [CODE]: KM.AKS.004



10.00 TL



KÖR BUJİ

PISTON STOP
TOOL

KOD [CODE]: T.AKS.007



4.30 TL

ALPINA



AMORTİSÖR
380-CX40

VIBRATION ISOLATOR
(380-CX40)

KOD [CODE]: KM.ALP.001



3.00 TL



AMORTİSÖR
40-45-C70-C90

VIBRATION ISOLATOR
(40-45-C70-C90)

KOD [CODE]: KM.ALP.002



3.50 TL

ALPINA



İP MAKARASI
380-CX40

STARTER PULLEY
(380-CX40)

KOD [CODE]: **KM.ALP.003**



5.80 TL



MARŞ TIRNAĞI
40-45-C70

STARTER PAWL
(40-45-C70)

KOD [CODE]: **CB.BEN.032**



2.50 TL

DOLMAR



AMORTİSÖR
111

VIBRATION ISOLATOR
(111)

KOD [CODE]: **KM.DOL.001**



4.50 TL



AMORTİSÖR,
112-116-120

VIBRATOR ISOLATOR
(112-116-120)

KOD [CODE]: **KM.DOL.002**



3.50 TL



AMORTİSÖR
123-133

VIBRATION ISOLATOR
(123-133)

KOD [CODE]: **KM.DOL.003**



4.00 TL



BENZİN HORTUMU
111

FUEL HOSE
(111)

KOD [CODE]: **KM.DOL.004**



4.50 TL



İP MAKARASI
116-120-133

STARTER PULLEY
(116-120-133)

KOD [CODE]: **KM.DOL.005**



7.50 TL



MAHMUZ İÇ
123-133

BUMPER SPIKE
(123-133)

KOD [CODE]: **KM.DOL.006**



3.50 TL

DOLMAR



MARŞ KAPAĞI
116-120

STARTER COVER
(116-120)

KOD [CODE]: **KM.DOL.007**



58.00 TL



MARŞ TIRNAĞI
116-120-133

STARTER PAWL
(116-120-133)

KOD [CODE]: **KM.DOL.008**



3.50 TL



TAŞIMA SAPI
116-120

HANDLEBAR
(116-120)

KOD [CODE]: **KM.DOL.009**



18.50 TL



TAŞIMA SAPI
123-133

HANDLEBAR
(123-133)

KOD [CODE]: **KM.DOL.010**



18.50 TL



YAĞ DİŞLİSİ
116-120-133

OIL PUMP DRIVE GEAR
(116-120-133)

KOD [CODE]: **KM.DOL.011**



6.50 TL



YAĞ DİŞLİSİ
133

OIL PUMP DRIVE GEAR
(133)

KOD [CODE]: **KM.DOL.012**



6.50 TL



YAĞ SACI DIŞ
116-120

GUIDE PLATE
(OUTER 116-120)

KOD [CODE]: **KM.DOL.013**



3.25 TL



YAĞ SACI İÇ
116-120

GUIDE PLATE
(INNER 116-120)

KOD [CODE]: **KM.DOL.014**



3.25 TL

HQ



**AMORTİSÖR
51-55**

VIBRATION
ISOLATOR (51-55)

KOD [CODE]: **KM.HUS.001**



2.65 TL



**AMORTİSÖR
61-268**

VIBRATION ISOLATOR
(61-268)

KOD [CODE]: **KM.HUS.002**



3.50 TL



**AMORTİSÖR 61
METRİK DİŞ**

VIBRATION ISOLATOR
(METRIC, 61)

KOD [CODE]: **KM.HUS.003**



3.50 TL



**AMORTİSÖR
61-268 ÖN**

VIBRATION ISOLATOR
(61-268)

KOD [CODE]: **KM.HUS.004**



3.50 TL



**AMORTİSÖR
281-288**

VIBRATION ISOLATOR
(281-288)

KOD [CODE]: **KM.HUS.005**



3.50 TL



**AMORTİSÖR
380-480-2100**

VIBRATION ISOLATOR
(380-480-2100)

KOD [CODE]: **KM.HUS.006**



3.50 TL



**BALATA PABUCU
61**

CLUTCH SHOE
(61)

KOD [CODE]: **KM.HUS.007**



24.00 TL



**BALATA YAYI
61-281-288**

CLUTCH SPRING
(61-281-288)

KOD [CODE]: **KM.HUS.008**



2.10 TL



**BALATA YAYI
268**

CLUTCH SPRING
(268)

KOD [CODE]: **KM.HUS.009**



0.80 TL



**BALATA YAYI
281-288**

CLUTCH SPRING
(281-288)

KOD [CODE]: **KM.HUS.010**



0.80 TL

HQ



BENZİN HORTUMU
281-288-2100

FUEL HOSE
(281-288-2100)

KOD [CODE]: KM.HUS.011



3.25 TL



BENZİN DEPO KAPAĞI
51-55-281-288

FUEL FILLER CAP
(51-55-281-288)

KOD [CODE]: KM.HUS.012



4.30 TL



BENZİN DEPO KAPAĞI
61-268

FUEL FILLER CAP
(61-268)

KOD [CODE]: KM.HUS.013



4.50 TL



BOĞAZ LASTİĞİ
51-55

RUBBER COMP.
(51-55)

KOD [CODE]: KM.HUS.014



2.75 TL



BUJİ TELİ

TORSION SPRING

KOD [CODE]: KM.HUS.015



1.00 TL



DİŞLİ REHBERİ

GUIDE DISC

KOD [CODE]: KM.HUS.016



1.75 TL



EGSOZ
61-268

MUFFLER
(61-268)

KOD [CODE]: KM.HUS.017



17.50 TL



EGSOZ CONTASI
61-268

EXHAUST GASKET
(61-268)

KOD [CODE]: KM.HUS.018



2.00 TL



EGSOZ DESTEK SACI
61-268

EXHAUST COVER
PLATE (61-268)

KOD [CODE]: KM.HUS.019



2.70 TL



EGSOZ DESTEK SACI
51-55

EXHAUST COVER PLATE
(51-55)

KOD [CODE]: KM.HUS.020



2.70 TL

HQ



GAZ TELİ
61-268

THROTTLE CABLE
(61-268)

KOD [CODE]: **KM.HUS.021**



1.75 TL



GAZ TELİ
40-45

THROTTLE CABLE
(40-45)

KOD [CODE]: **KM.HUS.022**



8.00 TL



GAZ TELİ
365

THROTTLE CABLE
(365)

KOD [CODE]: **KM.HUS.023**



8.00 TL



GAZ TETİĞİ
61-268

THROTTLE TRIGGER
(61-268)

KOD [CODE]: **KM.HUS.024**



5.50 TL



HAVA FİLTRESİ
61

AIR FILTER
(61)

KOD [CODE]: **KM.HUS.025**



7.50 TL



İP ÇEKME
SAPI

STARTER
GRIP

KOD [CODE]: **KM.HUS.026**



2.40 TL



İP MAKARASI
36

STARTER PULLEY
(36)

KOD [CODE]: **KM.HUS.027**



5.30 TL



İP MAKARASI
51-55

STARTER PULLEY
(51-55)

KOD [CODE]: **KM.HUS.028**



5.30 TL



İP MAKARASI
61-268

STARTER PULLEY
(61-268)

KOD [CODE]: **KM.HUS.029**



8.50 TL



İP MAKARASI
281-288

STARTER PULLEY
(281-288)

KOD [CODE]: **KM.HUS.030**



7.50 TL

HQ



İP MAKARASI
380-480

STARTER PULLEY
(380-480)

KOD [CODE]: KM.HUS.031



8.50 TL



JİKLE KOLU
51-55

CHOKE KNOB
(51-55)

KOD [CODE]: KM.HUS.032



3.90 TL



JİKLE KOLU
61-268-281-288

CHOKE KNOB
(61-268-281-288)

KOD [CODE]: KM.HUS.033



1.00 TL



KAPAK LASTİĞİ
KÜÇÜK 2100

RUBBER GROMMET
(SMALL 2100)

KOD [CODE]: KM.HUS.034



1.00 TL



KAPAK SOMUNU

COLLAR
NUT

KOD [CODE]: KM.HUS.035



0.50 TL



MAHMUZ
61-268

BUMPER SPIKE
(61-268)

KOD [CODE]: KM.HUS.036



3.75 TL



MARŞ TIRNAĞI
51-55

STARTER PAWL
(51-55)

KOD [CODE]: KM.HUS.037



3.25 TL



PALA SAPLAMASI
61-268

GUIDE BAR
BOLT

KOD [CODE]: KM.HUS.038



4.80 TL



ROLANTİ VİDASI
61-268

IGLE SPEED ADJUSTMENT
SCREW (61-268)

KOD [CODE]: KM.HUS.039



2.40 TL



STARTER ÇEMBERİ
51-55

STARTER INNER COVER
(51-55)

KOD [CODE]: KM.HUS.040



5.70 TL

HQ



STARTER ÇEMBERİ
61-268

STARTER INNER COVER
(61-268)

KOD [CODE]: **KM.HUS.041**



5.80 TL

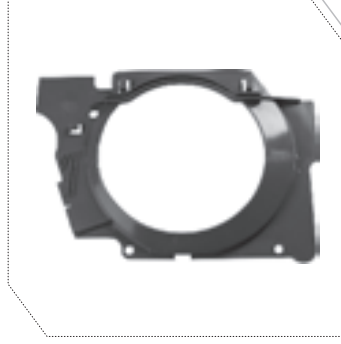

STARTER ÇEMBERİ
281-288

STARTER INNER COVER
(281-288)

KOD [CODE]: **KM.HUS.042**



5.80 TL



STARTER KAPAĞI
BOŞ 51-55

STARTER COVER
(51-55)

KOD [CODE]: **KM.HUS.043**



29.00 TL



STARTER KAPAĞI
51-55 KOMPLE

STARTER ASSY
(51-55)

KOD [CODE]: **KM.HUS.044**



45.00 TL



STOP ANAHTARI
51-55-65-268-281

ON/OFF SWITCH
(51-55-65-268-281)

KOD [CODE]: **KM.HUS.045**



7.60 TL



TAŞIMA SAPI
61-268

HANDLEBAR
(61-268)

KOD [CODE]: **KM.HUS.046**



17.00 TL



TIRNAK YAYI
61-268-281-288

STARTER PAWL SPRING
(61-268-281-288)

KOD [CODE]: **KM.HUS.047**



1.00 TL



YAĞ DIŞLİSİ
345

OIL PUMP DRIVE
GEAR (345)

KOD [CODE]: **KM.HUS.048**



4.80 TL



YAĞ DIŞLİSİ
51-55

OIL PUMP DRIVE
GEAR (51-55)

KOD [CODE]: **KM.HUS.049**



6.70 TL



YAĞ DIŞLİSİ
61-268

OIL PUMP DRIVE
GEAR (61-268)

KOD [CODE]: **KM.HUS.050**



1.90 TL

HQ



YAĞ DIŞLİSİ
281

OIL PUMP DRIVE
GEAR (281)

KOD [CODE]: **KM.HUS.051**



2.10 TL



YAĞ DIŞLİSİ
40-45

OIL PUMP DRIVE
GEAR (40-45)

KOD [CODE]: **KM.HUS.052**



6.70 TL



YAĞ DIŞLİSİ KOVANI
40-45

OIL PUMP DRIVE GEAR
COMP. (40-45)

KOD [CODE]: **KM.HUS.053**



6.70 TL



YAĞ DIŞLİSİ KOVANI
51-55

OIL PUMP DRIVE GEAR
COMP. (51-55)

KOD [CODE]: **KM.HUS.054**



6.70 TL



YAĞ KAPAĞI
51-55

OIL FILLER CAP
(51-55)

KOD [CODE]: **KM.HUS.055**



4.30 TL



YAĞ KAPAĞI
61-268

OIL FILLER CAP
(61-268)

KOD [CODE]: **KM.HUS.056**



4.30 TL



YAĞ HORTUMU
61-268-281

OIL HOSE
(61-268-281)

KOD [CODE]: **KM.HUS.057**



3.20 TL



YAĞ SACI
61-268

GUIDE PLATE
(61-268)

KOD [CODE]: **KM.HUS.058**



2.60 TL



YAĞ SACI
281-288-380

GUIDE PLATE
281-288-380

KOD [CODE]: **KM.HUS.059**



2.90 TL



YAĞ SACI DIŞ
281-288-380

GUIDE PLATE
(OUTER 281-288-380)

KOD [CODE]: **KM.HUS.060**



2.90 TL

HQ



YAĞ SÜZGEÇİ
61-268-281-288

OIL FILTER
(61-268-281-288)

KOD [CODE]: **KM.HUS.061**



8.00 TL



ZEMBEREK PLASTİĞİ
51-55

REWIND SPRING
COVER (51-55)

KOD [CODE]: **KM.HUS.062**



2.50 TL



ZİNCİR EMNİYETİ
51-55

BUMPER STRIP
(51-55)

KOD [CODE]: **KM.HUS.063**



2.50 TL



ZİNCİR EMNİYETİ
61-268

BUMPER STRIP
(61-268)

KOD [CODE]: **KM.HUS.064**



2.50 TL



ZİNCİR GERME
61-268-281-288

CHAIN TENSIONER
(61-268-281-288)

KOD [CODE]: **KM.HUS.065**



3.00 TL



ZİNCİR REHBERİ
61-268-281-288

CHAIN GUIDE

KOD [CODE]: **KM.HUS.066**



1.80 TL

JON



AMORTİSÖR
YAY 2065

VIBRATION ISOLATOR
(2065)

KOD [CODE]: **KM.JON.001**



5.70 TL



AMORTİSÖR YAY
2041-2045

VIBRATION ISOLATOR
(2041-2045)

KOD [CODE]: **KM.JON.002**



2.70 TL

JON



**AMORTİSÖR ALT
2041**

VIBRATION ISOLATOR
(BOTTOM 2041)

KOD [CODE]: **KM.JON.003**



2.70 TL



**DİŞLİ REHBERİ
625-630**

GUIDE DISC

KOD [CODE]: **KM.JON.004**



1.70 TL



**EGSOZ
625-630**

MUFFLER
(625-630)

KOD [CODE]: **KM.JON.005**



18.00 TL



**EGSOZ
CONTASI**

EXHAUST
GASKET

KOD [CODE]: **KM.JON.006**



1.90 TL



**EGSOZ DESTEK SACI
625-630**

EXHAUST COVER PLATE
(625-630)

KOD [CODE]: **KM.JON.007**



2.70 TL



**GAZ TELİ
2041-2045**

THROTTLE CABLE
(2041-2045)

KOD [CODE]: **KM.JON.008**



7.25 TL



**GAZ TETİĞİ
625-630**

THROTTLE TRIGGER
(625-630)

KOD [CODE]: **KM.JON.009**



5.70 TL



**HAVA FİLTRESİ
625-630**

AIR FILTER
(625-630)

KOD [CODE]: **KM.JON.010**



7.80 TL



**İP ÇEKME
SAPI**

STARTER
GRIP

KOD [CODE]: **KM.JON.011**



2.40 TL



**İP MAKARASI
630**

STARTER PULLEY
(630)

KOD [CODE]: **KM.JON.012**



7.50 TL

JON



**İP MAKARASI
625**

STARTER PULLEY
(625)

KOD [CODE]: **KM.JON.013**



9.00 TL



**İP MAKARASI
2065**

STARTER PULLEY
(2065)

KOD [CODE]: **KM.JON.014**



7.00 TL



**JİKLE KOLU
625-630**

CHOKE KNOP
(625-630)

KOD [CODE]: **KM.JON.015**



2.20 TL



**KAPAK SOMUNU
13 mm**

COLLAR NUT
(13 mm)

KOD [CODE]: **KM.JON.016**



0.50 TL



**MAHMUZ
625**

BUMPER SPIKE
(625)

KOD [CODE]: **KM.JON.017**



4.00 TL



**MAHMUZ
2041**

BUMPER SPIKE
(2041)

KOD [CODE]: **KM.JON.018**



4.25 TL



**MANİFOLD BORUSU
2041-2045**

MANIFOLD
(2041-2045)

KOD [CODE]: **KM.JON.019**



2.70 TL



**PALA SAPLAMASI
625-630**

GUIDE BAR BOLT
(625-630)

KOD [CODE]: **KM.JON.020**



4.70 TL



**ROLANTİ VİDASI
625-630**

IDLE SPEED ADJUSTMENT
SCREW (625-630)

KOD [CODE]: **KM.JON.021**



2.30 TL

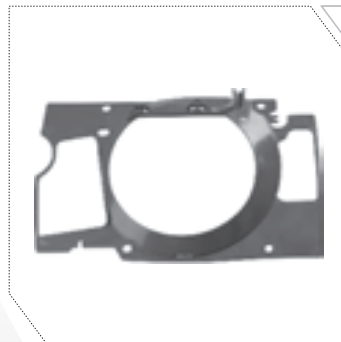

**STARTER ÇEMBERİ
625-630**

STARTER INNER COVER
(625-630)

KOD [CODE]: **KM.JON.022**



5.70 TL

JON

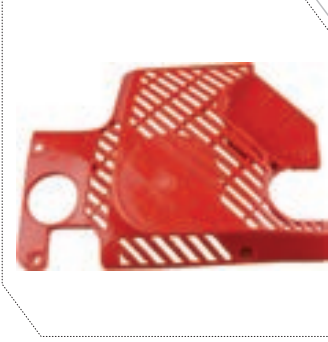

STARTER KAPAK
2041-2045

STARTER COVER
(2041-2045)

KOD [CODE]: KM.JON.023



29.00 TL



TAŞIMA SAPI
625-630

HANDLEBAR
(625-630)

KOD [CODE]: KM.JON.024



17.00 TL



TIRNAK YAYI
625-630

STARTER PAWL SPRING
(625-630)

KOD [CODE]: KM.JON.025



1.00 TL



YAĞ DIŞLISI
2041-2045

OIL PUMP DRIVE GEAR
(2041-2045)

KOD [CODE]: KM.JON.026



6.80 TL



YAĞ DIŞLISI
KOVANI

OIL PUMP DRIVE
GEAR COMP.

KOD [CODE]: KM.JON.027



6.80 TL



YAĞ HORTUMU
625-630

OIL HOSE
(625-630)

KOD [CODE]: KM.JON.028



3.25 TL



YAĞ SACI İÇ
(625-630)

GUIDE PLATE
(INNER, 625-630)

KOD [CODE]: KM.JON.029



3.00 TL



YAĞ SACI DIŞ
625-630

GUIDE PLATE
(OUTER, 625-630)

KOD [CODE]: KM.JON.030



3.00 TL



YAĞ SÜZGEÇİ
625-630

OIL FILTER
(625-630)

KOD [CODE]: KM.HUS.061



8.00 TL



ZİNCİR EMNİYETİ
625

BUMPER STRIP
(625)

KOD [CODE]: KM.JON.032



2.40 TL

JON



ZİNCİR GERME
625-630

CHAIN TENSIONER
(625-630)

KOD [CODE]: **KM.JON.033**



2.90 TL



ZİNCİR REHBERİ
625-630

CHAIN GUIDE
(625-630)

KOD [CODE]: **KM.JON.034**



1.75 TL

MCCULLOCH



AMORTİSÖR ALT
TİTAN 60

VIBRATION ISOLATOR
(BOTTOM, TITAN 60)

KOD [CODE]: **KM.MCC.001**



9.50 TL



AMORTİSÖR KOL
TİTAN 60

VIBRATION ISOLATOR
(TITAN 60)

KOD [CODE]: **KM.MCC.002**



12.50 TL



AMORTİSÖR
YAY

VIBRATION ISOLATOR
(SPRING)

KOD [CODE]: **KM.MCC.003**



3.50 TL



AMORTİSÖR
YAY ALT

VIBRATION ISOLATOR
(SPRING, BOTTOM)

KOD [CODE]: **KM.MCC.004**



2.80 TL



İP MAKARASI
484

STARTER PULLEY
(484)

KOD [CODE]: **KM.MCC.005**



7.50 TL



MARŞ TIRNAK
YAYI

STARTER PAWL
SPRING

KOD [CODE]: **KM.MCC.006**



1.90 TL

OLEO - MAC



AMORTİSÖR
272-350

VIBRATION ISOLATOR
(272-350)

KOD [CODE]: **KM.OLE.001**



2.10 TL



AMORTİSÖR
280-480

VIBRATION ISOLATOR
(280-480)

KOD [CODE]: **KM.OLE.002**



6.00 TL



AMORTİSÖR
961-962

VIBRATION ISOLATOR
(961-962)

KOD [CODE]: **KM.OLE.005**



3.50 TL



AMORTİSÖR
YAY

VIBRATION ISOLATOR
(SPRING)

KOD [CODE]: **KM.OLE.004**



2.65 TL



GAZ TELİ
B42-951-952

THROTTLE CABLE
(B42-951-952)

KOD [CODE]: **KM.OLE.005**



7.25 TL



İP MAKARASI
942

STARTER PULLEY
(942)

KOD [CODE]: **KM.OLE.006**



6.25 TL



MAHMUZ
941-942

BUMPER SPIKE
(941-942)

KOD [CODE]: **KM.OLE.007**



3.25 TL



TAŞIMA SAPI
956-961-962

HANDLEBAR
(956-961-962)

KOD [CODE]: **KM.OLE.008**



19.00 TL



YAĞ DIŞLISI
B42-951

OIL PUMP DRIVE
GEAR (B42-951)

KOD [CODE]: **KM.OLE.009**



8.00 TL



YAĞ LASTİĞİ
B42-951

ANGULAR NIPPLE
(B42-951)

KOD [CODE]: **KM.OLE.010**



5.50 TL

OLEO - MAC



YAĞ POMPA UCU
261-272

OIL PUMP COMP.
(261-272)

KOD [CODE]: **KM.OLE.011**



7.75 TL



ZİNCİR GERME
B42-941-942

CHAIN TENSIONER
(B42-941-942)

KOD [CODE]: **KM.OLE.012**



2.90 TL

POULON PARTNER



YAĞ DIŞLİSİ

OIL PUMP
DRIVE GEAR

KOD [CODE]: **KM.POU.001**



7.50 TL

STIHL



AMORTİSÖR
021-023-025

VIBRATION ISOLATOR
(021-023-025)

KOD [CODE]: **KM.STL.001**



2.70 TL



AMORTİSÖR
038

VIBRATION ISOLATOR
(038)

KOD [CODE]: **KM.STL.002**



7.50 TL

STIHL



**AMORTİSÖR
028**

VIBRATION ISOLATOR
(028)

KOD [CODE]: KM.STL.003



2.75 TL



**AMORTİSÖR
034**

VIBRATION ISOLATOR
(034)

KOD [CODE]: KM.STL.004



2.75 TL



**AMORTİSÖR
034 ALT**

VIBRATION ISOLATOR
(BOTTOM 034)

KOD [CODE]: KM.STL.005



2.75 TL



**AMORTİSÖR
038**

VIBRATION ISOLATOR
(038)

KOD [CODE]: KM.STL.006



2.75 TL



**AMORTİSÖR
029-039**

VIBRATION ISOLATOR
(029-039)

KOD [CODE]: KM.STL.007



2.75 TL



**AMORTİSÖR
041**

VIBRATION ISOLATOR
(041)

KOD [CODE]: KM.STL.008



6.50 TL



**AMORTİSÖR
042-048**

VIBRATION ISOLATOR
(042-048)

KOD [CODE]: KM.STL.009



8.25 TL



**AMORTİSÖR 051
ALT KOL**

VIBRATION ISOLATOR
(BOTTOM 051)

KOD [CODE]: KM.STL.010



7.75 TL



**AMORTİSÖR 01
ÜST KABZE**

VIBRATION ISOLATOR
(ABOVE 051)

KOD [CODE]: KM.STL.011



7.75 TL



**AMORTİSÖR ALT KOL
045-056**

VIBRATION ISOLATOR
(BOTTOM 045-056)

KOD [CODE]: KM.STL.012



8.50 TL

STIHL



AMORTİSÖR ÜST KABZE
045-056

VIBRATION ISOLATOR
(ABOVE 045-056)

KOD [CODE]: **KM.STL.013**



8.50 TL



AMORTİSÖR ALT KABZE
070

VIBRATION ISOLATOR
(BOTTOM 070)

KOD [CODE]: **KM.STL.014**



7.50 TL



AMORTİSÖR BAKLAVA
045-056

VIBRATION ISOLATOR
045-056

KOD [CODE]: **KM.STL.015**



8.50 TL



BALATA YAYI
051

CLUTCH SPRING
(051)

KOD [CODE]: **KM.STL.016**



0.75 TL



BENZİN HORTUMU
038

FUEL HOSE
(038)

KOD [CODE]: **KM.STL.017**



4.50 TL



BENZİN HORTUMU
070

FUEL HOSE
(070)

KOD [CODE]: **KM.STL.018**



1.25 TL



BENZİN DEPO KAPAĞI
038

FUEL FILLER CAP
(038)

KOD [CODE]: **KM.STL.036**



4.50 TL



BUJİ BAŞLIĞI
070

SPARK PLUG BOOT
(070)

KOD [CODE]: **KM.STL.019**



3.25 TL



FİLTRE KAPAĞI
08

FILTER CAP
(08)

KOD [CODE]: **KM.STL.101**



4.65 TL



GAZ TETİĞİ
51

THROTTLE TRIGGER
(51)

KOD [CODE]: **KM.STL.021**



5.50 TL

STIHL



GAZ TETİĞİ
070

THROTTLE TRIGGER
(070)

KOD [CODE]: **KM.STL.022**



5.50 TL



İP MAKARASI
064

STARTER PULLEY
(064)

KOD [CODE]: **KM.STL.023**



5.50 TL



İP MAKARASI
09-010

STARTER PULLEY
(09-010)

KOD [CODE]: **KM.STL.024**



5.50 TL



İP MAKARASI
021-023-025

STARTER PULLEY
(021-023-025)

KOD [CODE]: **KM.STL.025**



5.50 TL



İP MAKARASI
029-039

STARTER
(029-039)

KOD [CODE]: **KM.STL.026**



5.50 TL



İP MAKARASI
034

STARTER PULLEY
(034)

KOD [CODE]: **KM.STL.027**



5.50 TL



İP MAKARASI
051

STARTER PULLEY
(051)

KOD [CODE]: **KM.STL.028**



11.00 TL



İP MAKARASI
045-056

STARTER PULLEY
(045-056)

KOD [CODE]: **KM.STL.029**



11.00 TL



İP MAKARASI
070

STARTER PULLEY
(070)

KOD [CODE]: **KM.STL.030**



11.00 TL



KAPAK SOMUNU
021-023-025-029-039

COLLAR NUT
(13 mm)

KOD [CODE]: **KM.STL.031**



11.00 TL

STIHL



MARŞ TIRNAĞI
021-023-025

STARTER PAWL
(021-023-025)

KOD [CODE]: **KM.STL.032**



1.75 TL



MARŞ TIRNAĞI
029-034-039

STARTER PAWL
(029-034-039)

KOD [CODE]: **KM.STL.033**



1.75 TL



RİNG PLASTİK
08-045-056

PLASTIC RING
(08-045-056)

KOD [CODE]: **KM.STL.034**



2.75 TL



TIRNAK YAYI
021-023-025

STARTER PAWL SPRING
(021-023-025)

KOD [CODE]: **KM.STL.035**



1.75 TL



YAĞ DEPO KAPAĞI
038

OIL FILLER CAP
(038)

KOD [CODE]: **KM.STL.037**



4.50 TL

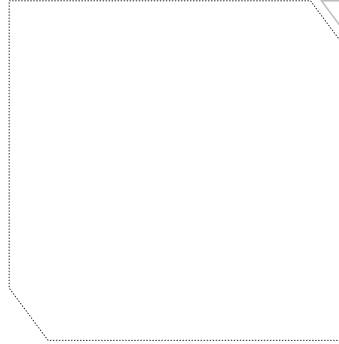

GAZ TETİĞİ
08

THROTTLE TRIGGER
(08)

KOD [CODE]: **KM.STL.036**



5.00 TL

P.R.C.



İP MAKARASI
DAR DELİK

ROPE PULLEY
(NARROW HOLE)

KOD [CODE]: **KM.PRC.001**



4.50 TL



İP MAKARASI
GENİŞ DELİK

ROPE PULLEY
(WIDE HOLE)

KOD [CODE]: **KM.PRC.002**



4.50 TL



ÇAPA MAKİNESİ YEDEK PARÇALARI

TILLER SPARE PARTS

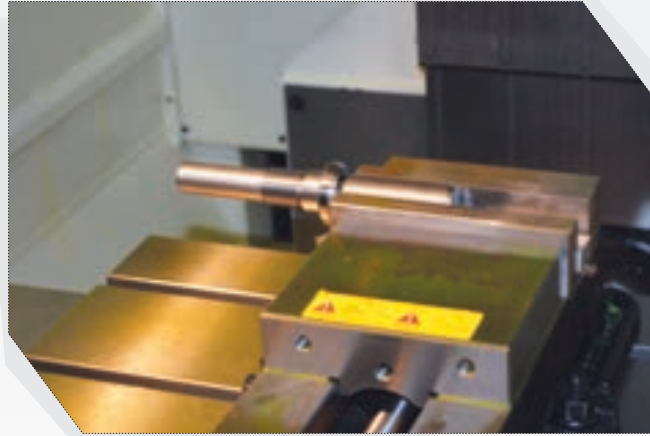

ÇAPA MAKİNESİ // TILLER



BÜYÜK DİŞLİ BAĞLANTISI

BIG GEAR CONNECTOR

KOD [CODE]: CM.001



Bilgi Alınız.



BÜYÜK DİŞLİ SACI DİŞ

PLATE ASSY. FOR BIG GEAR (OUTER)

KOD [CODE]: CM.002



Bilgi Alınız.



ÇAMURLUK ALT

MUDGUARD (BOTTOM)

KOD [CODE]: CM.003



Bilgi Alınız.



ÇAMURLUK SAĞ

MUDGUARD (RIGHT)

KOD [CODE]: CM.004



Bilgi Alınız.



ÇAMURLUK SOL

MUDGURAD (LEFT)

KOD [CODE]: CM.005



Bilgi Alınız.

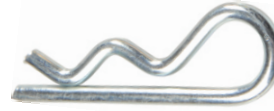

ÇAPA BAĞLANTI PİMİ SEGMANI

HITCH PIN CLIP

KOD [CODE]: CM.006



Bilgi Alınız.



ÇAPA BAĞLANTI PİMİ KISA

A CLEVIS PIN (SHORT)

KOD [CODE]: CM.007



Bilgi Alınız.



ÇAPA BAĞLANTI PİMİ UZUN

A CLEVIS PIN (LONG)

KOD [CODE]: CM.008



Bilgi Alınız.



ÇAPA BIÇAĞI SOL

BLADE (LEFT)

KOD [CODE]: CM.009



Bilgi Alınız.



ÇAPA BIÇAĞI SAĞ

BLADE (RIGHT)

KOD [CODE]: CM.010



Bilgi Alınız.

ÇAPA MAKİNESİ // TILLER



**ÇAPA
DİŞLİSİ**

GEAR FOR
TILLER

KOD [CODE]: **CM.055**



Bilgi
Alınız.



**ÇAPA
DİŞLİSİ 2**

GEAR FOR
TILLER 2

KOD [CODE]: **CM.056**



Bilgi
Alınız.

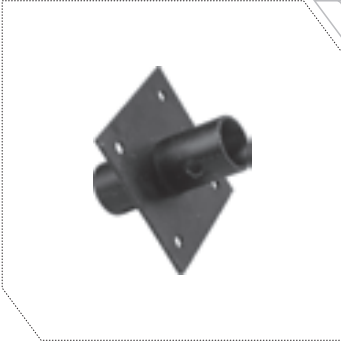

**ÇAPA BİÇAĞI BAĞLANTI
BORUSU KISA**

BLADE CONNECTOR PIPE
(SHORT TYPE)

KOD [CODE]: **CM.011**



Bilgi
Alınız.

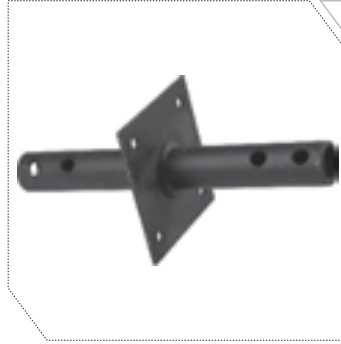

**ÇAPA BİÇAĞI BAPLANTI
BORUSU UZUN**

BLADE CONNECTOR PIPE
(LONG TYPE)

KOD [CODE]: **CM.012**



Bilgi
Alınız.

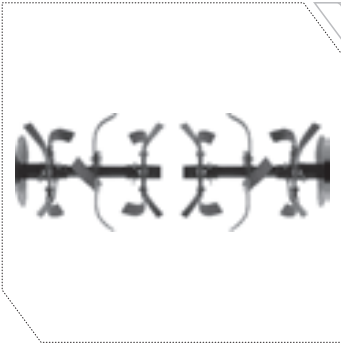

**ÇAPA BİÇAĞI
TAKIM**

BLADE SET

KOD [CODE]: **CM.013**



Bilgi
Alınız.



**ÇİZGİ DEMİRİ BAĞLANTI
PARÇASI**

CAST CONNECTOR COMP.
FOR MAKING LINE

KOD [CODE]: **CM.014**



Bilgi
Alınız.



**DİŞLİ BAĞLANTI
MİLİ**

GEAR CONNECTOR
BOLT

KOD [CODE]: **CM.015**



Bilgi
Alınız.



**DİŞLİ BAĞLANTI
BURCU**

GEAR CONNECTOR
BUSHING

KOD [CODE]: **CM.016**



Bilgi
Alınız.



ELCİK

HANDLE
GRIP

KOD [CODE]: **CM.017**



Bilgi
Alınız.



**GAZ KOLU
KOMPLE**

THROTTLE LEVER
ASSEMBLY

KOD [CODE]: **CM.018**



Bilgi
Alınız.

ÇAPA MAKİNESİ // TILLER



**GAZ TELİ AYAR
CİVATASI**

THROTTLE LEVER
ADJUSTER

KOD [CODE]: **CM.019**



**Bilgi
Alınız.**



**GÖVDE KORUMA
PLASTİĞİ**

PLASTIC COVER
(INNER)

KOD [CODE]: **CM.020**



**Bilgi
Alınız.**



**GÖVDE KORUMA
PLASTİĞİ DIŞ**

PLASTIC COVER
(OUTER)

KOD [CODE]: **CM.021**



**Bilgi
Alınız.**



**İLERİ - GERİ HAREKET
DİŞLİSİ TAKIM**

DRIVE GEAR
SET

KOD [CODE]: **CM.022**



**Bilgi
Alınız.**



**İLERİ - GERİ HAREKET
KOLU**

LEVER HANDLE (FORWARD
AND BACK GEAR)

KOD [CODE]: **CM.023**



**Bilgi
Alınız.**



**İLERİ - GERİ VİTES
BAĞLANTI AYAĞI**

LEVER HANDLE CONNECTOR
ASSY.

KOD [CODE]: **CM.024**



**Bilgi
Alınız.**



**İLERİ - GERİ VİTES
BAĞLANTI AYAĞI KOMPLE**

LEVER HANDLE
SET

KOD [CODE]: **CM.025**



**Bilgi
Alınız.**



**İLERİ - GERİ HAREKET
TELİ**

LEVER CABLE (FORWARD
AND BACK GEAR)

KOD [CODE]: **CM.026**



**Bilgi
Alınız.**



**KAPAK
DIŞ**

OUTER COVER

KOD [CODE]: **CM.027**



**Bilgi
Alınız.**



KAPAK İÇ

INNER COVER
PLATE

KOD [CODE]: **CM.028**



**Bilgi
Alınız.**

ÇAPA MAKİNESİ // TILLER



**KASNAK
LASTİK**

GROOVED
PULLEY

KOD [CODE]: **CM.029**



Bilgi
Alınız.



**KAYIŞ BASKI AYAĞI
BÜYÜK**

METAL COMP. FOR PRESSING
BELT (BIG TYPE)

KOD [CODE]: **CM.030**



Bilgi
Alınız.



**KAYIŞ BASKI AYAĞI
KÜÇÜK**

METAL COMP. FOR PRESSING
BELT (SMALL TYPE)

KOD [CODE]: **CM.031**



Bilgi
Alınız.



**KAYIŞ BASKI
MAKARASI**

BELT PRESS
PULLEY

KOD [CODE]: **CM.032**



Bilgi
Alınız.



**KAYIŞ BASKI YAYI
KÜÇÜK**

BELT PRESS SPRING
(SMALL)

KOD [CODE]: **CM.033**



Bilgi
Alınız.



**KAYIŞ BASKI YAYI
BÜYÜK**

BELT PRESS SPRING
(BIG)

KOD [CODE]: **CM.034**



Bilgi
Alınız.



**KAYIŞ
GERİ**

V - BELT
(BACK)

KOD [CODE]: **CM.035**



Bilgi
Alınız.



**KAYIŞ
İLERİ**

V - BELT
(FORWARD)

KOD [CODE]: **CM.036**



Bilgi
Alınız.



**KOD BAĞLANTI
KELEPÇESİ**

HANDLEBAR
CONNECTOR

KOD [CODE]: **CM.037**



Bilgi
Alınız.



**KOL BAĞLANTI VİDASI
SOMUNLU**

BOLTS AND NUTS FOR
HANDLEBAR CONNECTOR

KOD [CODE]: **CM.038**



Bilgi
Alınız.

ÇAPA MAKİNESİ // TILLER



KOL DİREKSİYON

HANDLEBAR

KOD [CODE]: **CM.039**



Bilgi Alınız.



MOTOR HAREKET DİŞLİSİ

DRIVE GEAR

KOD [CODE]: **CM.040**



Bilgi Alınız.



**MOTOR HAREKET DİŞLİSİ
20 - 19 mm**

DRIVE GEAR
(20 - 19 mm)

KOD [CODE]: **CM.041**



Bilgi Alınız.



**MOTOR KASNAĞI
(PULİ)**

ENGINE PULLEY

KOD [CODE]: **CM.042**



Bilgi Alınız.



**ŞANZUMAN BAĞLANTI
ARA PARÇASI**

GEARCASE COMP.

KOD [CODE]: **CM.054**



Bilgi Alınız.



**ŞANZUMAN DİŞLİSİ
BÜYÜK**

GEAR (BIG)

KOD [CODE]: **CM.043**



Bilgi Alınız.



**ŞANZUMAN DİŞLİSİ
KÜÇÜK**

GEAR (SMALL)

KOD [CODE]: **CM.044**



Bilgi Alınız.



**ŞANZUMAN DİŞLİSİ
ORTA**

GEAR (MIDDLE)

KOD [CODE]: **CM.045**



Bilgi Alınız.



**ŞANZUMAN
KOMPLE**

GEAR CASE
(FULL)

KOD [CODE]: **CM.046**



Bilgi Alınız.



**ŞANZUMAN BLOK
SAĞ - SOL**

GEAR CASE COVER
(RIGHT - LEFT)

KOD [CODE]: **CM.047**



Bilgi Alınız.

ÇAPA MAKİNESİ // TILLER



ŞASE

CHASSIS

KOD [CODE]: **CM.048**



Bilgi
Alınız.



TEKERLEK

WHEEL

KOD [CODE]: **CM.049**



Bilgi
Alınız.



**TEKERLEK BAĞLANTI
AYAĞI**

STAND OF
WHEEL

KOD [CODE]: **CM.050**



Bilgi
Alınız.



**YÜKSEKLİK AYAR
DEMİRİ**

HEIGHT LEVER

KOD [CODE]: **CM.051**



Bilgi
Alınız.



**ZİNCİR
KÜÇÜK**

CHAIN (SMALL)

KOD [CODE]: **CM.052**



Bilgi
Alınız.



**ZİNCİR
BÜYÜK**

CHAIN (BIG)

KOD [CODE]: **CM.053**



Bilgi
Alınız.



ZEYTİN TOPLAMA MAKİNESİ YEDEK PARÇALARI

OLIVE HARVESTER SPARE PARTS



ZEYTİN TOPLAMA // OLIVE HARVESTER



EMR400 BUDAMA APARATI

PRUNER ATTACHMENT

KOD [CODE]: ZTM.039



Bilgi Alınız.



KANCA

HOOK

KOD [CODE]: ZTM.001



Bilgi Alınız.

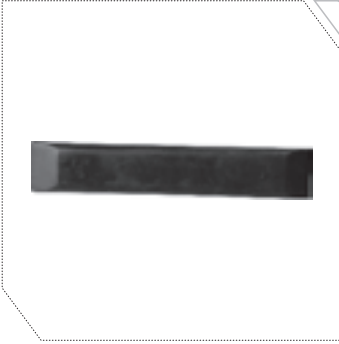

KANCA LASTİĞİ

HOOK RUBBER

KOD [CODE]: ZTM.002



Bilgi Alınız.



ŞANZUMAN KOMPLE

GEARCASE

KOD [CODE]: ZTM.003



Bilgi Alınız.



ŞANZUMAN KAPAĞI

GEARCASE COVER

KOD [CODE]: ZTM.004



Bilgi Alınız.

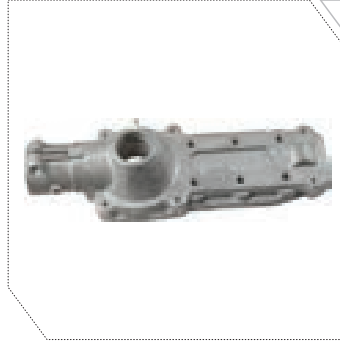

ŞANZUMAN GÖVDE

GEARCASE HOUSING

KOD [CODE]: ZTM.005



Bilgi Alınız.



BİLYA CİVATA KAPAĞI

BEARING AND BOLT COVER

KOD [CODE]: ZTM.006



Bilgi Alınız.



BORU BAĞLANTI SOMUNU

RUBBER CONNECTOR FOR FLEXIBLE SHAFT

KOD [CODE]: ZTM.007



Bilgi Alınız.



HAREKET DİŞLİSİ PİMİ

DRIVE GEAR PIN

KOD [CODE]: ZTM.008



Bilgi Alınız.



HAREKET DİŞLİSİ BÜYÜK

RING GEAR

KOD [CODE]: ZTM.009



Bilgi Alınız.

ZEYTİN TOPLAMA // OLIVE HARVESTER



**HAREKET DİŞLİSİ
KÜÇÜK**

PINION GEAR

KOD [CODE]: ZTM.010



**Bilgi
Alınız.**



**HAREKET DİŞLİSİ
TAKIM**

RING AND PINION
GEAR

KOD [CODE]: ZTM.011



**Bilgi
Alınız.**



**HAREKET
MİLİ**

DRIVE SHAFT

KOD [CODE]: ZTM.012



**Bilgi
Alınız.**

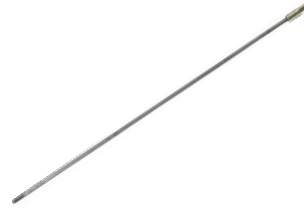

**HAREKET MİLİ
KOMPLE**

DRIVE SHAFT
(SET)

KOD [CODE]: ZTM.013



**Bilgi
Alınız.**



**HAREKET MİLİ
EKLEME**

JOINT SHAFT

KOD [CODE]: ZTM.014



**Bilgi
Alınız.**



**HAREKET MİLİ EKLEME
SOMUNLU**

JOINT SHAFT
(WITH NUT)

KOD [CODE]: ZTM.015



**Bilgi
Alınız.**



**KAPAK CİVATA VE
SOMUNU**

BOLT AND NUT OF
GEARCASE COVER

KOD [CODE]: ZTM.016



**Bilgi
Alınız.**



**KIZAK - MAKARA
BAĞLANTI CİVATASI**

SLIDE GUIDE
BOLT

KOD [CODE]: ZTM.017



**Bilgi
Alınız.**



KOL KISA

DRIVE SHAFT AND ALUMINIUM
PIPE SET (SHORT)

KOD [CODE]: ZTM.018



**Bilgi
Alınız.**



KOL UZUN

DRIVE SHAFT AND ALUMINIUM
PIPE SET (LONG)

KOD [CODE]: ZTM.019



**Bilgi
Alınız.**

ZEYTİN TOPLAMA // OLIVE HARVESTER



KOL LASTİĞİ

HANDLE HOSE

KOD [CODE]: ZTM.020



Bilgi Alınız.



KRANK BİLYASI VE BURCU

NEEDLE BEARING

KOD [CODE]: ZTM.021



Bilgi Alınız.



KRANK KOLU

CRANK CONNECTING ROD

KOD [CODE]: ZTM.022



Bilgi Alınız.

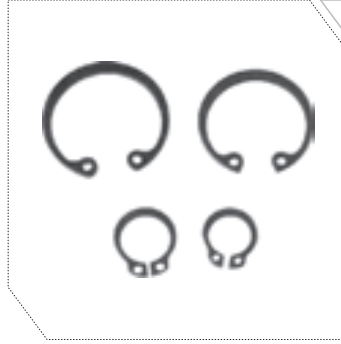

SEGMAN GRUBU

PISTON RING SET

KOD [CODE]: ZTM.023



Bilgi Alınız.

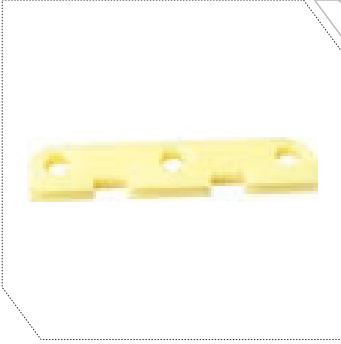

SİLME KIZAĞI

SLIDE GUIDE

KOD [CODE]: ZTM.024



Bilgi Alınız.

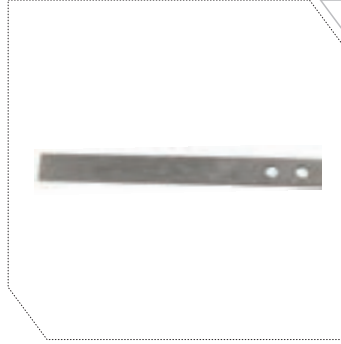

KANCA BAĞLANTI SACI KISA

SLIDE PLATE (SHORT)

KOD [CODE]: ZTM.025



Bilgi Alınız.

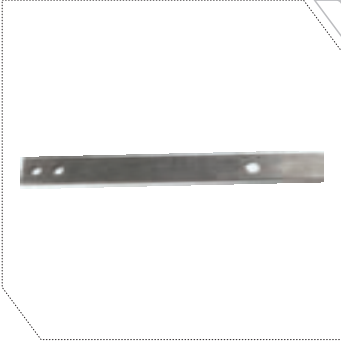

KANCA BAĞLANTI SACI

SLIDE PLATE (LONG)

KOD [CODE]: ZTM.026



Bilgi Alınız.



SİLME HAREKET BURCU

SLIDE PIN

KOD [CODE]: ZTM.027



Bilgi Alınız.



SİLME KIZAK BİLYASI

SLIDE BEARING

KOD [CODE]: ZTM.028



Bilgi Alınız.



SİLME TOZLUĞU

SLIDE PLATE CLEANER

KOD [CODE]: ZTM.029



Bilgi Alınız.

ZEYTİN TOPLAMA // OLIVE HARVESTER



SPIRAL MİL GİRİŞİ

DRIVE SHAFT CONNECTOR

KOD [CODE]: ZTM.030



Bilgi Alınız.



TETİK GRUBU

LEVER ASSEMBLY

KOD [CODE]: ZTM.031



Bilgi Alınız.



DIŞLİ BİLYASI BÜYÜK

GEAR BEARING (BIG)

KOD [CODE]: ZTM.032



Bilgi Alınız.



DIŞLİ BİLYASI KÜÇÜK

GEAR BEARING (SMALL)

KOD [CODE]: ZTM.033



Bilgi Alınız.



HAREKET DIŞLİ BAĞLANTI PULU BÜYÜK

GEAR WASHER (BIG)

KOD [CODE]: ZTM.034



Bilgi Alınız.



HAREKET DIŞLİ BAĞLANTI PULU KÜÇÜK

GEAR WASHER (SMALL)

KOD [CODE]: ZTM.035



Bilgi Alınız.

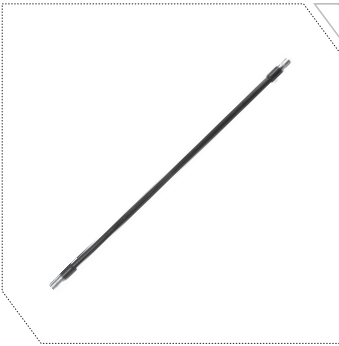

SPIRAL HORTUM BLUEBIRD

FLEXIBLE SHAFT (BLUEBIRD)

KOD [CODE]: ZTM.036



Bilgi Alınız.

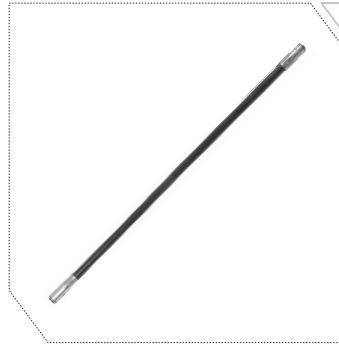

SPIRAL HORTUM OLEOMAC / EFCO

FLEXIBLE SHAFT (OLEOMAC / EFCO)

KOD [CODE]: ZTM.037



Bilgi Alınız.



FİRMA ADI : KADIOĞLU MAKİNE YED. PRÇ. MOT. İML. İNŞ. SAN. TİC. LTD. ŞTİ.
ADRES : OTO SANAYİ SİTESİ 4.SK.9.BLOK NO: 134/ 136/ 138 YILDIRIM / BURSA
VERGİ DAİRESİ/NO : GÖKDERE/ 486 039 57 31
TEL/FAX : 0 224 342 40 33/ 342 39 46

HESAP NUMARALARI;

İŞBANKASI OTOSANATKARLARI ŞUBESİ (2228), 0006502 HS.

IBAN NO : TR75 0006 4000 0012 2280 006502 (KADIOĞLU MAKİNE)

İŞBANKASI OTOSANATKARLARI ŞUBESİ (2228), 0000020 HS.

IBAN NO : TR04 0006 4000 0012 2280 0000 20 (SALİH EMRE)

YAPIKREDİ BANKASI DUAÇINARI ŞUBESİ (595), 80979478 HS.

IBAN NO : TR81 0006 7010 0000 0080 979478(KADIOĞLU MAKİNE)

YAPIKREDİ BANKASI DUAÇINARI ŞUBESİ (595), 66857386 HS.

IBAN NO : TR41 0006 7010 0000 0066 857386 (SALİH EMRE)

AKBANK YILDIRIM ŞUBESİ (574), 0080450 HS.

IBAN NO : TR98 0004 6005 7488 8000 080450(KADIOĞLU MAKİNE)

AKBANK YILDIRIM ŞUBESİ(574), 0034304 HS.

IBAN NO : TR75 0004 6005 7488 8000 034304 (SALİH EMRE)

GARANTİ BANKASI ANKARA CADDESİ ŞB(246), 6297949 HS.

IBAN NO : TR94 0006 2000 2460 0006 297949 (KADIOĞLU MAKİNE)

HALK BANKASI ERTUĞRULGAZİ/BURSA ŞB(0291),10260227 HS.

IBAN NO : TR30 0001 2009 2910 0010 260227(KADIOĞLU MAKİNE)

HALK BANKASI ERTUĞRULGAZİ/BURSA ŞB(0291),10260227 HS.

IBAN NO : TR30 0001 2009 2910 0010 260227(KADIOĞLU MAKİNE)

PTT POSTA ÇEK HESABI;

HESAP NO : 112 65 34 (SABİT EMRE / ERTUĞRULGAZİ ŞUBESİ)

ONLINE TAHSİLAT SİSTEMİ;

- KREDİ KARTI İLE TAKSİTLİ ÖDEME
www.kadioglumakina.com.tr



- **Fiyatlarımıza KDV Dahildir**, katalogta yazılan fiyatlar iskontosuz fiyatlardır. İskonto oranınızı öğrenmek için firmamızla irtibata geçiniz.
- Kadiođlu Makina katalogtaki fiyatları, İskonto oranlarını önceden haber vermeksizin deđiřtirebilir.
- Firmamıza banka havalesi yapıldığında firmamız yazılı olarak bilgilendirilmelidir.
- Katalogtaki yazım hatalarından Kadiođlu Makina Ltd. řti. sorumlu tutulamaz.
- Kargo bedeli alıcıya alıcı tarafından karřılanacaktır.
- Katalog ierisindeki resimlerin ve yazıların tüm kullanım hakları firmamıza aittir.
- Katalogta yer alan yedek paralar, orijinal olmayan yan sanayi ürünlerdir. Belirtilen isimler sadece uyum tavsiyesi için yazılmıştır.

Kadiođlu Tarım Makineleri ve Yedek Para San. Tic. Ltd. řti.

Ankara Cad. Otosansit Sanayi Sitesi 9. Blok No: 134-136-138 Yıldırım / BURSA / TÜRKİYE

Tel.: +90.224 342 40 33 - Faks: +90.224 342 39 46

info@kadmec.com / aliemre@kadmec.com



Kadiođlu Makine İmalat San. Tic. Ltd. Őti.
Ankara Cd. Yiđitler Mh. Otosansit Sanayi Sitesi
9. Blok No: 134 - 138 Bursa / TURKEY
Tel.: +90224 342 40 33 Fax: +90224 342 39 46
www.kadmec.com
www.kadmectrimmerheads.com
info@kadmec.com

B.T. Mart 2014
Bu Katalog Kosgeb Desteđi İle HazırlanmıŐtır.
www.akmat.com.tr www.kosgeb.gov.tr

